

# ULTRASONIC DISTANCE SENSORS

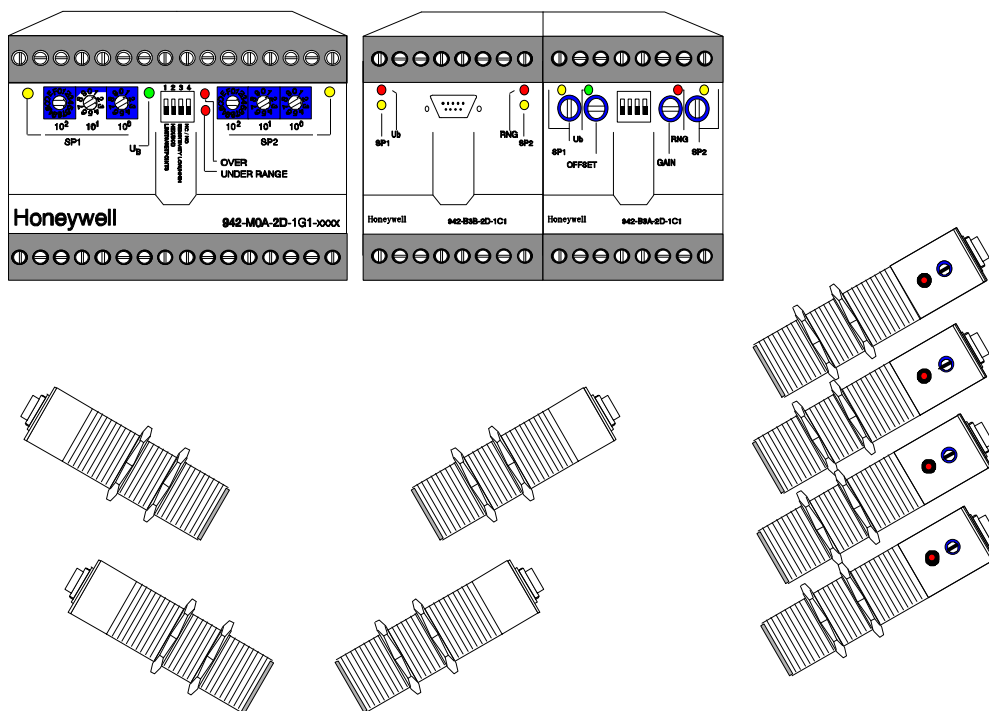

## MANUAL PROGRAMMING THE P42 SENSOR SERIES

	PAGE
INTRODUCTION	
How to use this manual	3
PROGRAMMING OF SENSORS WITH RS232 INTERFACE	4
Structure of Memory Organisation	4
Hardware set-up	5
Programming Adapter	6
RS 232 - RS 485 Converter	8
Structure of Commands	9
Commands	10
Software	23
Software Tools	25
PROGRAMMING OF SENSORS	28
P42-M3A-2D-1G1-300E / -220S /-180E / -130E	28
Listings	29
Function switches	30
Set point adjustment	31
Technical data	31
Wiring	32
Sensor heads	33
Programming the P42-M3A-2D-1G1-XXXX sensor series	35
List of commands	35
Geometry	38
Examples	39
P42-A4N-2D-1C1-300E /-220S /-130E	42
P42-A4N-2D-1D1-220S /-130E	
P42-A4N-2D-1E1-220S /-130E	
Listings	43
Technical data	44
Wiring	45
Programming the P42-A4N-2D-1C/D/E/F-XXXX sensor series	46
List of commands	46
Geometry	50
Examples	51
INDEX	54
CROSS - REFERENCE LIST	61

## INTRODUCTION

### HOW TO USE THIS MANUAL

This manual should help the user to program sensors of series P42

Basics are described in chapter **Programming of Sensors with RS232 Interface**

This chapter contains a general overview of

- structure of memory in the P42 series,
- hardware set-up,
- structure of commands,
- special registers
- and a description of the very important software tools  
**UDSE.EXE** and **SENDE.EXE**  
Software **UDSDEMO.EXE**

In the chapter **Programming of the Sensors** the specific characteristics of each sensor is listed. The programmer should start directly with the sensor he wants to program.

The rubric **Programming** lists all commands available.

**Examples** shows specific applications and their realisation.

## PROGRAMMING OF SENSORS WITH RS232 INTERFACE

### STRUCTURE OF MEMORY ORGANISATION

The memory organisation of the P42 series is shown in the following sketch:

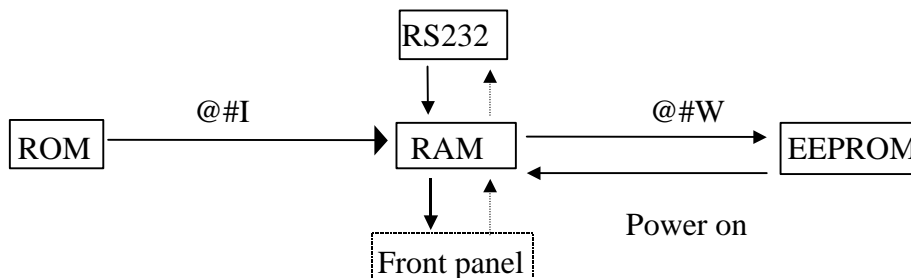

The **RAM** could get information from different sources:

1. **EEPROM**

By connecting the power supply to the sensor, the data from the EEPROM will be loaded into the RAM

2. **ROM**

With a special command the factory setting is shifted from the ROM into the RAM.

3. **RS 232**

Via the RS 232 interface the user has direct access to the RAM.

4. **Front Panel**

The front panel of the P42-M0A... and P42-B0A... enables the change of some settings in the RAM.

From the **RAM** information can be communicated to:

1. **EEPROM**

The actual setting can be stored.

2. **RS 232**

Via RS 232 the actual distance information or status information can be communicated to the PC.

3. **Font Panel**

The front LEDs of the front panel can be driven directly.

## HARDWARE SET-UP

The most effective way to change settings of the sensor is the programming with a PC via the RS 232 interface.

For this use

- **baud rate of PC has to be set to 9600 baud, no parity, 8 bit 2 stop bits. \***
- **the sensor should be run in the 'hold' mode (connection of the HLD-input with GND), to avoid data collisions on the interface.**
- **the connection SENSOR - PC has to be done the following way:**

\*Programs UDSE.EXE; SENDE.EXE or UDSDEMO.EXE are setting the interface COM1 or COM2 in the needed mode.

Sensor					PC		
B0B-...	B0A-...	M3A-...	A4M-1C/D.	Function	Function		
SubMinD9	Screw	Screw	PIN			SubMinD9	SubMinD25
3	12	20	5	TXD----	RXD	2	3
2	11	22	6	RxD----	TxD	3	2
5	10	21	3	GND----	GND	5	7

The connection of pins (DTR-DSR-CTS) of the PC connector is necessary for programs using the MS-DOS Int 14h (for example DOS, BASIC, GWBASIC,...).

With some PC's the level of the TxD signal is too small. This can be shifted with the sketched circuit.

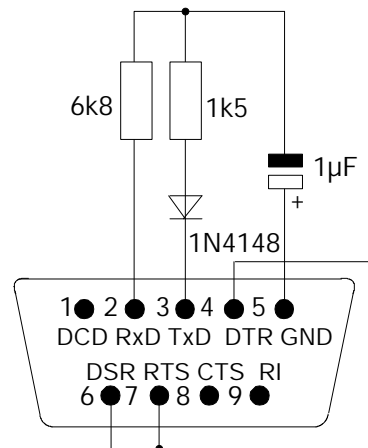
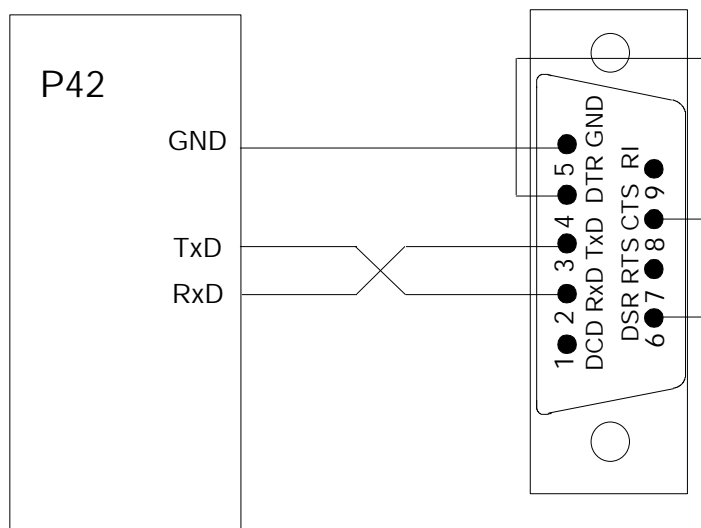

Pin connection from outside PC.

## PROGRAMMING ADAPTER

A very useful tool for the programming of the compact P42-A4N-... series is the **PROGRAMMING ADAPTER**

Listing: **P55000005-002**

It can be mounted directly to an installed sensor. The sensor has to be disconnected and between the two connectors the programming module can be inserted.

This programming module has a SubMiniD9 connector, identical with most laptop COM interfaces. With a standard RS232 cable the connection between programming module and PC can be done.

It also has two LEDs indicating the status of the switching outputs and switch to set the sensor in the hold mode.

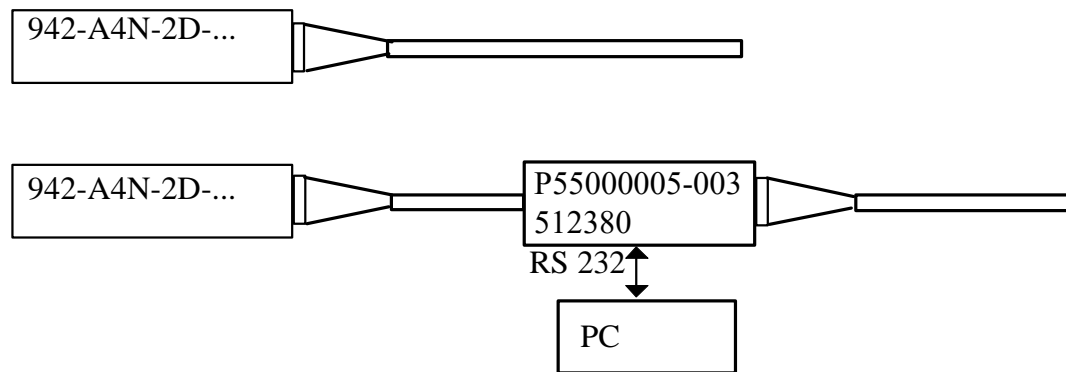

Advantages:

- Easy access with a laptop to the RS 232 lines.
- Programming can be done in close proximity to the sensor.
- TxD-, RxD- and HLD/Sync lines do not need to be installed.
- Status of set points can be surveyed.
- No limitation in cable length. (Length of RS 232 cable should be limited to 2 m)

The following drawings show the adapter and its electrical circuit.

# PROGRAMMING OF SENSORS WITH RS232 INTERFACE

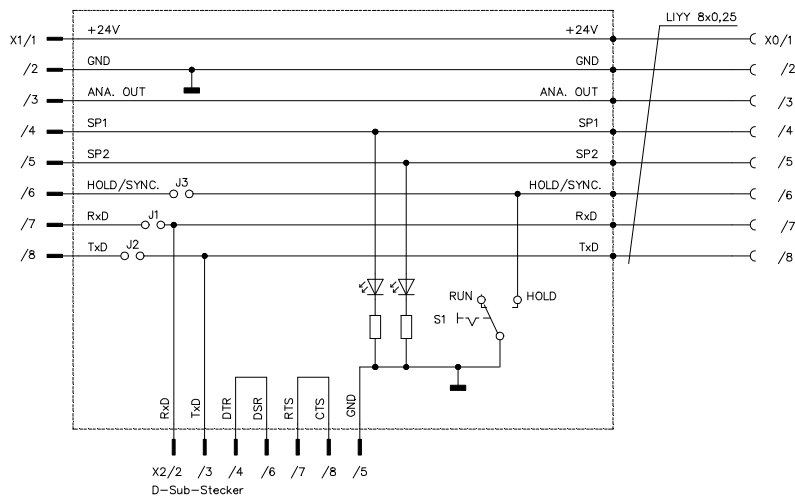
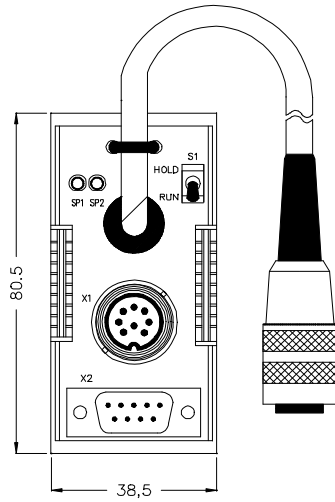

Electrical circuit programming module

## RS 232 - RS 485 CONVERTER

Some sensors the P42-A4N-2D-1E/F.... series are equipped with a RS 485 interface. Programming is exactly the same as with RS 232 interface.

A RS 232 - RS 485 converter is available.

This small device can be mounted on a DIN rail and enables the communication with all RS485 sensors.

P55000003-002  
512377

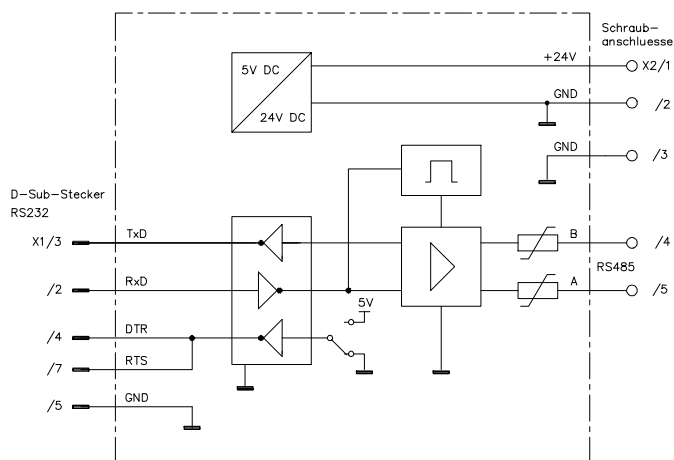
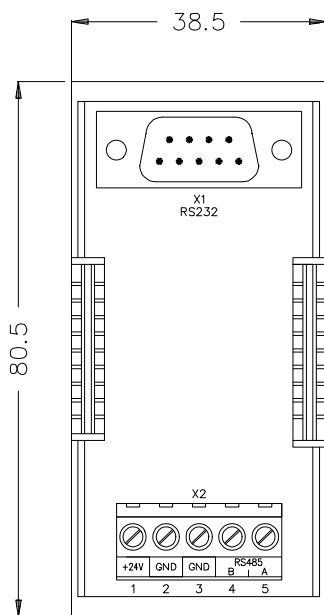



## STRUCTURE OF COMMANDS

The sensors can be adjusted to its special application with a set of commands, transmitted via the RS 232 (RS 485) interface.

Special commands exist for setting of following parameters:

**Set points of switching outputs,  
Hysteresis,  
Characteristics of switching outputs (NO or NC),  
Analogue output range,  
Offset of analogue output,  
Under range (Dead zone),  
Over range counter,  
Cycle time,  
Transmission time of ultrasonic pulse,  
Adjustment of sensor offset,  
Fail pulse suppression,  
Setting of MODE register**

This list might vary, depending on sensor type.

The actual settings can be:

**Stored into the EEPROM,  
Display on the screen or  
Copied into a file in the PC**

Each command has the same structure: **@abp<CR>**

with:

@ - Start of command, always identical  
a - Address of the sensor, in addition every sensor responds to the address '#'  
b - Command  
<CR> - End of command <CR> = ENTER = #13

After receiving the 'End of command' <CR> the sensor change it's operation.

## COMMANDS

In this chapter a description of the most important commands is listed. A detailed list of commands for each sensor with a description of their functions can be found in the chapter describing the special sensor series.

### WRITE FACTORY SETTING INTO RAM

**@aI<CR>**

The initial factory setting will be written from the ROM into the RAM. If the sensor was programmed incorrectly and doesn't operate the way it should; by using this command the sensor can be restored to its original Factory Setting.

### WRITE ACTUAL SETTING INTO EEPROM

**@aW<CR>**

The actual sensor settings can be written into the EEPROM, so, when the power supply of the sensor is switched off and on again the settings from the EEPROM will be loaded into the RAM.

### READ OUT SENSOR SETTINGS

**@aD<CR>**

The command **@aD<CR>** will cause the sensor to send 8 (9) words of the actual setting via the RS 232 (RS 485) interface. This information contains:

- MODE register,**
- Set points of switching outputs,**
- Hysteresis,**
- Analogue output range,**
- Offset of analogue output,**
- Under range (Dead zone),**
- Over range counter,**
- Cycle time,**
- Transmission time of ultrasonic pulse,**
- Adjustment of sensor offset,**
- Fail pulse suppression**

The information is in HEX format. As one word contains 8 bit, some of the words are divided into 2 parts with 4 bits, containing different information.

The specific list for each sensor you will find in the chapter describing the special sensor series.

## CHANGE SENSOR ADDRESS

### @aAp<CR>

This command changes address from 'a' to ASCII value of p: ASC(p). For example @aA98<CR> renames sensor address from a to b (ASC(98)=b).

All sensors have in addition the address '#'. This is important, if the sensor address is unknown.

Following addresses can be used:

ASCII table:

Dec.	Chr.	Dec.	Chr.	Dec.	Chr.	Dec.	Chr.	Dec.	Chr.
97	a	107	k	117	u	127	•	137	ë
98	b	108	l	118	v	128	Ç	138	è
99	c	109	m	119	w	129	ü	139	ï
100	d	110	n	120	x	130	é	140	î
101	e	111	o	121	y	131	â	141	ì
102	f	112	p	122	z	132	ä	142	Ä
103	g	113	q	123	{	133	à	143	Å
104	h	114	r	124		134	å	144	É
105	i	115	s	125	}	135	ç	.	
106	j	116	t	126	~	136	ê	.	

## CYCLE TIME ADJUSTMENT

### @aCp<CR> p = 64; 32; 16; 8; 4 msec

Measurement principle of the distance measurement is shown in the following drawing.

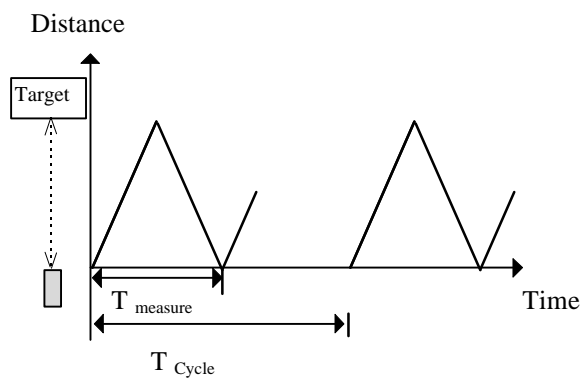

The sensor (grey) is transmitting an ultrasonic pulse along the dotted line to the target. At the target surface it will be deflected back to the sensor where it will be received.

In the diagram the position of the pulse versus time is shown.

Starting from the sensor face to the target, back to the sensor and once more reflected in the direction to the target. The end of this line indicates that the intensity of the ultrasonic pulse is so small that it cannot be detected anymore. Now the next measurement can be taken and a new ultrasonic pulse can be transmitted.

The time between transmissions of the pulses is called the cycle time  $T_{\text{cycle}}$ .

Cycle time determines the response time of the sensor. Obviously sensors used for long distance measurement also have long response times. With the programming of the cycle time the response time of the sensor can be adjusted to the application.

**Cycle time must always be longer than the time needed to absorb the transmitted ultrasonic pulse!**

The time of flight of the pulse (Sensor-Target-Sensor):  $T_{\text{measure}}$  is proportional to the distance of the object. This time is measured and transformed in the corresponding distance.

In the following table a maximum distance for given cycle times is proposed:

Command	Cycle time ms	Distance m
@aC4<CR>	4	0.3
@aC8<CR>	8	0.7
@aC16<CR>	16	2.5
@aC32<CR>	32	4.5
@aC64<CR>	64	10.

For more information see also: **MEASUREMENT WINDOW**

## UNDER RANGE ADJUSTMENT

**@aUp<CR>**  $0 \leq p \leq 255$  cm

During transmission ultrasonic transducers cannot receive ultrasonic pulses. Each sensor has it's own characteristic zone in front of it, where objects cannot be detected. This zone is called 'DEAD ZONE'.

With this command this zone can be enlarged. Parameter p - length of the zone - starts at the sensor face. Echoes in this zone will be ignored.

Disturbing objects in front of the sensors can be ignored, choosing the right setting for the under range. See sketch.

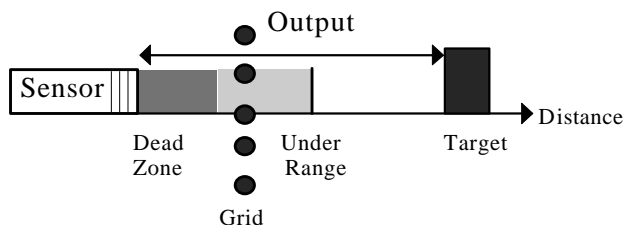

A sensor can detect targets for example through a protecting grid without being disturbed by the reflection of this grid.

Example 1: SMALL OBJECT

Under range and offset of the analogue range of a sensor are identical.

Analogue output 0 to 10 V has positive slope. A small target is moved towards the sensor head.

In the diagram the output is shown decreasing to 0V at the start of the under range and remains at 0 until point X where it jumps to 10V.

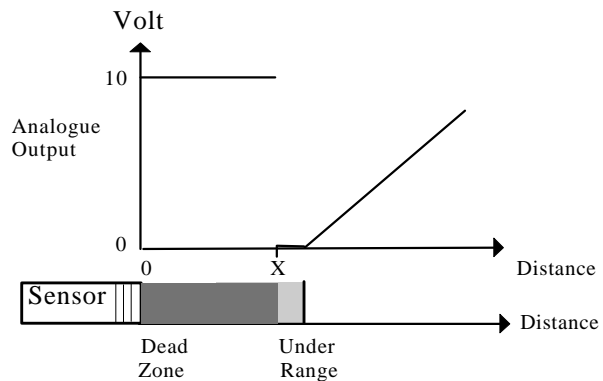

Following table shows distance X depending on the value of the under range adjustment:

Command	p	X cm
@aU20<CR>	20	14
@aU30<CR>	30	22
@aU40<CR>	40	32
@aU50<CR>	50	42
@aU100<CR>	100	85
@aU200<CR>	200	178

**Limitations:**

- **Minimum under range is determined by the transducer ringing. p=0 has no effect.**
- **Echoes of a massive target in the dead zone will be suppressed, but 2nd or 3rd echoes can be received if their time of flight is longer than the programmed dead zone. Output will then display a distance corresponding 2 or 3 times of the real one.**

Example 2: LARGE OBJECT

Offset of the analogue range of a sensor = 0, analogue output 0 to 10 V has positive slope. A large target is moved from far to the sensor head.

In the drawing the output is shown.

It is decreasing until the start of the under range, where it drops to 0 V and remains at 0 V until point X it then jumps back up (It may than jump to undefined values caused by double echoes).

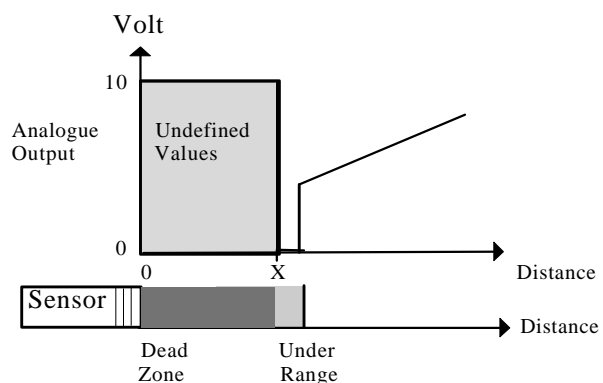

## SET POINT ADJUSTMENT

### SET POINT 1

**@a1p<CR>**  $0 \leq p \leq 10000$  mm

### SET POINT 2

**@a2p<CR>**  $0 \leq p \leq 10000$  mm

Defines the status of the switching PNP outputs depending of the distance of the target and whether it is set to NO or NC characteristics.

See also Hysteresis, Switching Window

NO: Distances higher than selected set point, the output is high resistant.

Distances lower, equal selected set point, the output is low resistant, current flow up to 100 mA.

NC: Distances higher than selected set point, the output is low resistant, current flow up to 100 mA.

Distances lower, equal selected set point, the output is high resistant.

## HYSTERESIS SET POINT 1

**@aHp<CR>**  $0 \leq p \leq 255$  mm

## HYSTERESIS SET POINT 2

**@aGp<CR>**  $0 \leq p \leq 255$  mm

To avoid a flickering of the switching output if the measured distance corresponds exactly to the set point a hysteresis can be programmed. See also Switching Window.

Example for NO output characteristic:

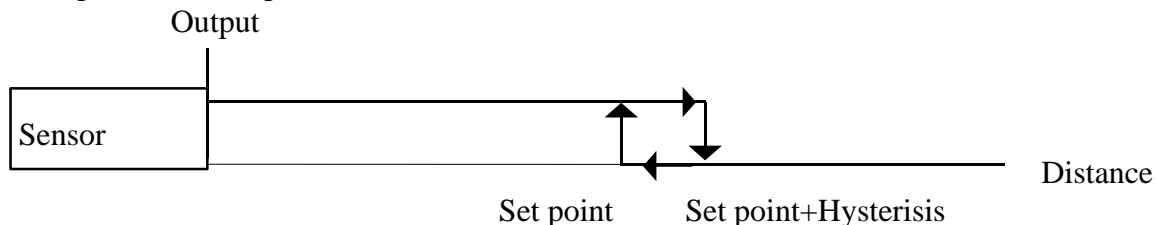

If an object is approaching the sensor from large distance, output will change at distance = set point.

If the object now returns, the change of the output will be at the distance = set point+hysteresis.

## SWITCHING WINDOW

Some of the sensors can be driven in the mode '**Switching Window**'. This can be selected by setting the corresponding bit. In this mode the sensor is switching if the target is in the range between set point and set point+hysteresis.

Example for NO output characteristic:

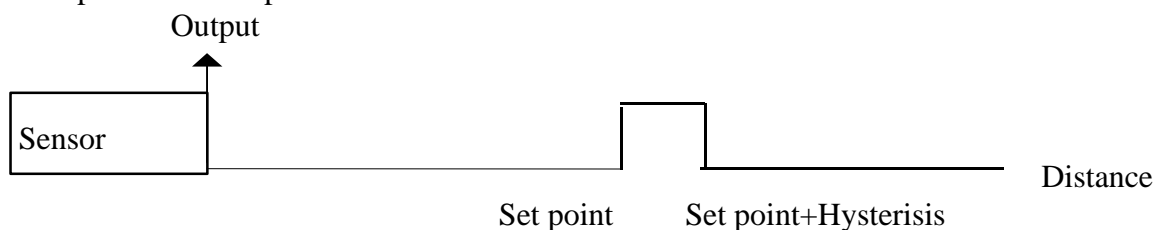

## ANALOGUE OUTPUT

The analogue output is set with two commands

### OFFSET AND RANGE

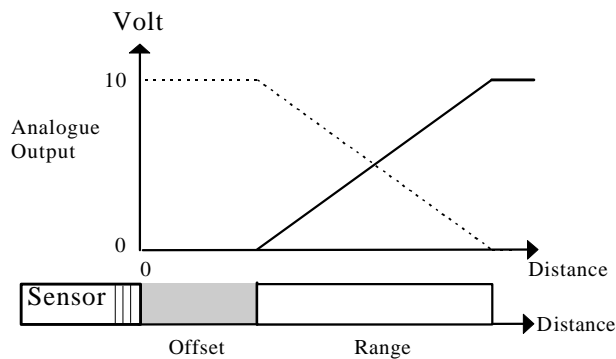

### OFFSET OF THE ANALOGUE OUTPUT

**@aOp<CR>**  $0 \leq p \leq 255$  cm;  $0 \leq p \leq 10000$  mm

Offset of the analogue output is the distance from the sensor head to the beginning of the analogue output range. The parameter p defines the distance in cm or mm.

### RANGE OF THE ANALOGUE OUTPUT

**@aSp<CR>**  $0 \leq p \leq 255$  cm;  $0 \leq p \leq 10000$  mm

Analogue output range is the range where the analogue output is changing between 0 to 10 V or 4 to 20 mA. The parameter p defines the length of the range in cm or mm.

## MODE REGISTER

**@aMp<CR>**

Sensor characteristics can be programmed by setting bits in the **MODE** register for adjustment of the following functions:

- Enable/disable input via front panel**
- Enable/disable serial asynchronous data output**
- Positive/negative slope of analogue output**
- Output with/without mean value routine**
- NO/NC characteristics of switching outputs**
- Switching window characteristic of switching output**
- HEX/BCD digital output of the serial interface**

Determination the value of the parameter 'p' for programming the Mode register.

This register is an 8 bit word. Each bit has a special function. It can be selected dependent of it's value 0 or 1.

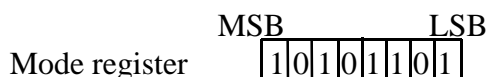

Here MSB stands for Most Significant Bit value: 128 and LSB for the Lowest Significant Bit value: 1.

Example:

The Mode register of the P42-A4N-2D-1C1-XXX allows following settings:

Mode register Description	bit	value	MSB	LSB
Output if target betw. Sp and SP+Hyst. Limit switch	1	* 128		
RS 232 data output disabled	0	* 64		
RS 232 data output enabled	1	* 32		
Special function Normal operation	0	* 16		
Negative slope of analogue output	1	* 8		
Positive slope of analogue output	0	* 4		
Output without mean value	1	* 2		
Output with mean value	0	* 1		
Switch 2 is NC	1	* 4		
Switch 2 is NO	0	* 2		
Switch 1 is NC	1	* 1		
Switch 1 is NO	0	* 1		
Digital output in BCD	1	* 1		
Digital output in HEX	0	* 1		

Selecting the following settings the value of the Mode register parameter is the sum of all values:

Mode register Description	bit	value	MSB	LSB
Output if target betw. Sp and SP+Hyst	1	1*128= 128		
RS 232 data output enabled	0	0* 64= 0		
Normal operation	0	0* 32= 0		
Negative slope of analogue output	1	1* 16= 16		
Output with mean value	0	0* 8= 0		
Switch 2 is NO	0	0* 4= 0		
Switch 1 is NC	1	1* 2= 2		
Digital output in BCD	1	1* 1= 1		

$$p = \Sigma(\text{values(bits)}) = 147$$

The command for the setting is: @#M147<CR>

For each sensor series a special MODE register exists. You will find it in detail in the chapter: Programming of Sensors.



## OFFSET ADJUSTMENT OF SENSOR

**@aXp<CR>**  $1 \leq p \leq 255$  mm

There can be a difference between distance output of the sensor and the real distance. The position of the distance 0 of the output and the location of the sensor face can differ. The position of the 0 can be adjusted with the sensor head offset adjustment.

$0 < p < 128$  is for positive offset shift, when the 0 of the distance output is in front of the sensor face.  $126 < p < 256$  is for negative offset shift, when the 0 of the distance output is behind the sensor face in the sensor.

Example for negative offset:

Offset -30 mm, the sensor output differs 30 mm. Output shows a value 30 mm too far.

Parameter p for negative values has to be calculated the following way:

$$p = -30 + 256 = 226$$

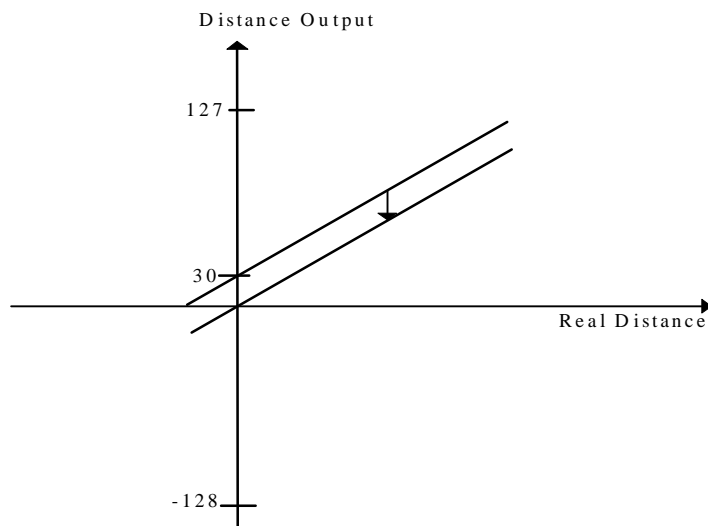

The offset can be adjusted with @aX226<CR>

## OVER RANGE COUNTER

**@aRp<CR>**  $1 \leq p \leq 255$

If the sensor has to measure the distance to a small target which is difficult to detect, it might happen that the sensor outputs will be very unstable. They will flicker between the actual distance and over range.

Controlling a process with these outputs might result in a catastrophe. These abrupt changes can be suppressed with the **over range counter**. It's operation is shown in the flow chart:

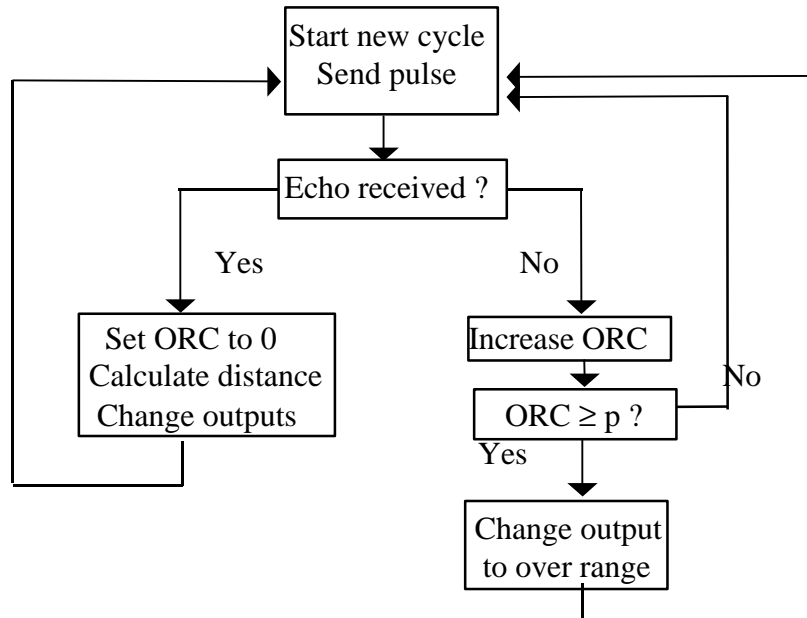

At the beginning of the measurement cycle, sensor is transmitting an ultrasonic pulse.

If an echo is received, the over range counter ORC will be set to 0, and the new measured distance calculated, if necessary the outputs changed and then the next ultrasonic pulse transmitted.

If no echo is received, the over range counter ORC will be increased.

If ORC below the parameter p no changes in the output will be made, the sensor will transmit a pulse during the next measurement cycle.

If ORC is equal or higher than p, outputs will be changed to over range and the sensor will transmit a pulse during the next measurement cycle.

Example:

A sensor with the following setting:

@aC64<CR>

@aR200<CR>

If suddenly the target disappears, the sensor needs  $200 \times 64 \text{ ms} = 12.8 \text{ s}$  until it's outputs change to over range.

## FAIL PULSE SUPPRESSION

Sensor electronics are well protected against electromagnetic disturbances of the environment. In addition the microprocessor is used in a very effective way to filter the right signal out of noisy environment.

In this chapter the interested reader will be informed about the mechanism how fail pulse suppression by software is realised.

Factory settings are optimised to fulfil most of the measurement tasks. But sometimes in very special applications these information can be helpful to understand the behaviour of the sensor and to adapt it the best way.

With the **Mean Value Bit** in the **Mode Register** the software filtering and fail echo suppression is activated.

Around the actual measured distance a window is created with the size of normally  $\pm 32$  mm. This window is called **Measurement Window**. (For adjustment of this measurement window see the special point Measurement Window. )

If the next measurement / new value is within this measurement window it will be used to calculate the new distance which will then be displayed. Around this actual distance a new measurement window is placed.

Two counters one 'A' for the lock-out of the actual distance and the other 'B' for the lock-in are set to 0.

If the next measurement / new value is outside this measurement window this measurement will be ignored and the distance output will be unchanged.

The counter counting the number of measurements outside which are not in the measurement window is increased from 0 to 1.

If the **Lock Out Counter A** is below 3 (programmable) the program jumps back to the start and a new measurement is made.

If it is higher or equal 3 the **Lock In Counter B** is increased.

If  $B = 1$ , the measured value is assumed to be the new distance and a new measurement window is created. The program jumps back to the start and a new measurement is made.

If  $B > 1$  and the new measurement is outside the new measurement window, **B** is set to 1 and the program jumps back to the start and a new measurement is made.

If  $B = 4$  (programmable) the new measurement now is realised as the new distance. Output is now changed and the lock out and lock in counters are set to 0. The program jumps back to the start and a new measurement is made.

The following diagram shows the different steps of the program.

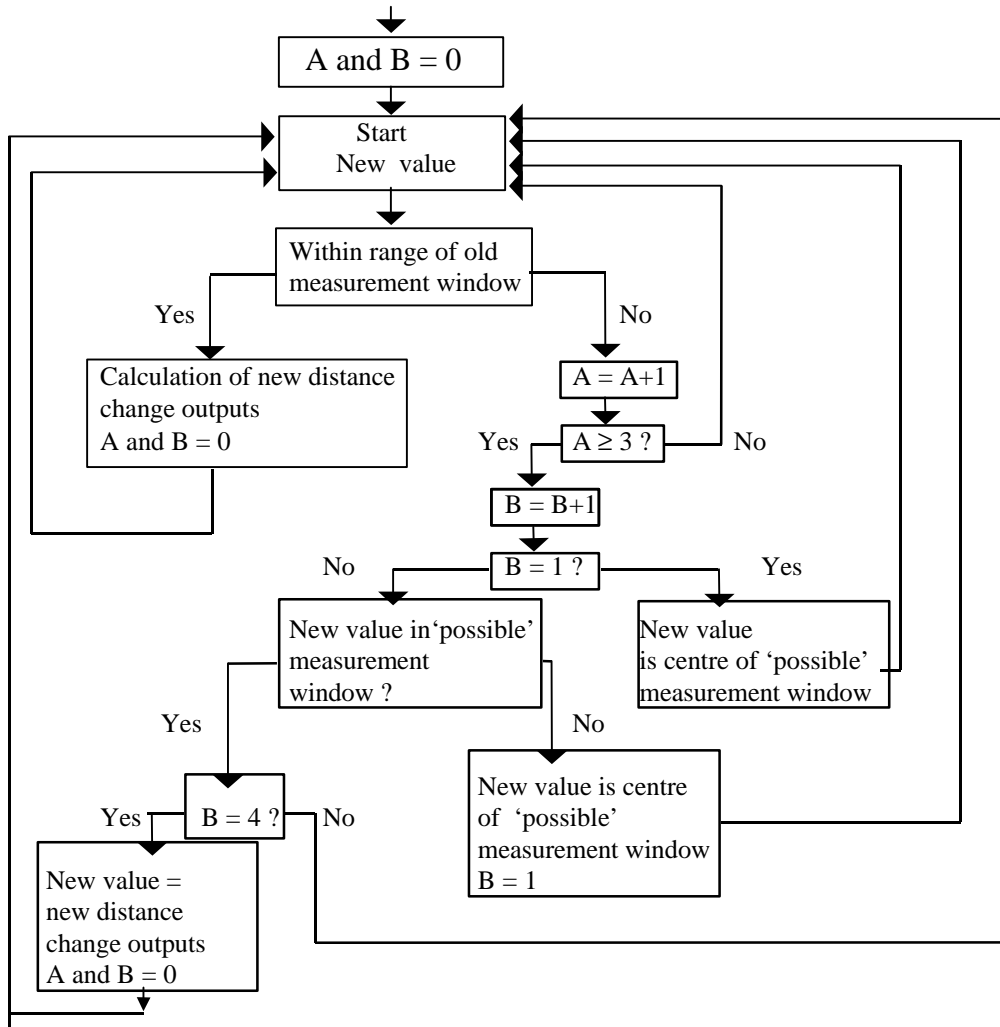

### LOCK OUT / LOCK IN COUNTER ADJUSTMENT

**@aTp<CR>**  $1 \leq p \leq 255$   
**@aTp<CR> @aEp<CR>**  $1 \leq p \leq 255^*$

The values for counters A and B as described above can be set with the command T. Parameter p corresponds to a 8 bit, where the above 4 bits are used for the Lock In Counter B and the lower 4 bits are for the Lock Out counter A.

@aT67<CR> sets the Lock In Counter B to 4 and Lock Out Counter A to 3; HEX 43 corresponds to DEC 67. See BCD-HEX conversion list.

\* In series P42-M0A-2D-1G1-xxxx the Lock-out and Lock-in counter are programmed separately with the commands:

**@aTp<CR> @aEp<CR>**

## MEASUREMENT WINDOW

Operating the sensor with the mean value routine - the bit 'OUTPUT WITH MEAN VALUE' is set in the mode register- a window is created around the actual measured distance.

Measured distance values which are in this window will be taken into account for the calculation of the new distance. This new distance is then the new centre of the measurement window. The window is moving with the target movement.

The maximum speed of the window movement limits the speed of a target which should be detected. If the target moves faster, distance measurements will be ignored by the fail pulse suppression algorithm.

The maximum speed depends on the cycle time and on the size of the used measuring window.

With the command of cycle time adjustment it is also possible to adjust the measurement window.

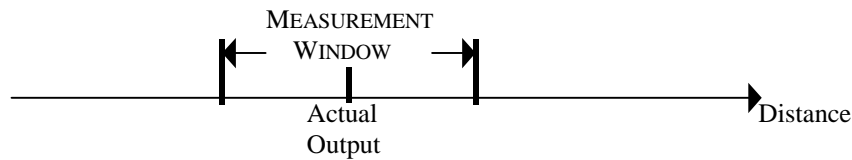

Normal size of this measurement window is  $\pm 32$  mm.

### Cycle Time and Measurement Window Adjustment

@aCp<CR>

The command adjusting the cycle time can also be used for the Measurement Window adjustment. Following table is showing for different values of P the CYCLE TIME, the size of the MEASUREMENT VALUE and the MAXIMUM SPEED of the MEASUREMENT WINDOW.

COMMAND	CYCLE TIME ms	WINDOW $\pm$ mm	MAX . SPEED OF WINDOW cm/s
@aC0<CR>	4	32	400
@aC1<CR>	4	2	24
@aC2<CR>	4	4	50
@aC3<CR>	4	8	100
@aC4<CR>	4	16	200
@aC5<CR>	4	32	400
@aC6<CR>	4	64	800
@aC7<CR>	4	128	1600
@aC8<CR>	8	32	200
@aC9<CR>	8	2	12
@aC10<CR>	8	4	25
@aC11<CR>	8	8	50
@aC12<CR>	8	16	100
@aC13<CR>	8	32	200
@aC14<CR>	8	64	400
@aC15<CR>	8	128	800

PROGRAMMING OF SENSORS WITH RS232 INTERFACE

COMMAND	CYCLE TIME ms	WINDOW ± mm	MAX . SPEED OF WINDOW cm/s
@aC16<CR>	16	32	100
@aC17<CR>	16	2	6
@aC18<CR>	16	4	12
@aC19<CR>	16	8	25
@aC20<CR>	16	16	50
@aC21<CR>	16	32	100
@aC22<CR>	16	64	200
@aC23<CR>	16	128	400
@aC32<CR>	32	32	50
@aC33<CR>	32	2	3
@aC34<CR>	32	4	6
@aC35<CR>	32	8	12
@aC36<CR>	32	16	25
@aC37<CR>	32	32	50
@aC38<CR>	32	64	100
@aC39<CR>	32	128	200
@aC64<CR>	64	32	25
@aC65<CR>	64	2	2
@aC66<CR>	64	4	3
@aC67<CR>	64	8	6
@aC68<CR>	64	16	12
@aC69<CR>	64	32	25
@aC70<CR>	64	64	50
@aC71<CR>	64	128	100

BCD - HEX CONVERSION LIST

	0	1	2	3	4	5	6	7	8	9
0	0	1	2	3	4	5	6	7	8	9
10	A	B	C	D	E	F	10	11	12	13
20	14	15	16	17	18	19	1A	1B	1C	1D
30	1E	1F	20	21	22	23	24	25	26	27
40	28	29	2A	2B	2C	2D	2E	2F	30	31
50	32	33	34	35	36	37	38	39	3A	3B
60	3C	3D	3E	3F	40	41	42	43	44	45
70	46	47	48	49	4A	4B	4C	4D	4E	4F
80	50	51	52	53	54	55	56	57	58	59
90	5A	5B	5C	5D	5E	5F	60	61	62	63
100	64	65	66	67	68	69	6A	6B	6C	6D
110	6E	6F	70	71	72	73	74	75	76	77
120	78	79	7A	7B	7C	7D	7E	7F	80	81
130	82	83	84	85	86	87	88	89	8A	8B
140	8C	8D	8E	8F	90	91	92	93	94	95
150	96	97	98	99	9A	9B	9C	9D	9E	9F
160	100	101	102	103	104	105	106	107	108	109

For example: 88 BCD corresponds to 58 HEX

## SOFTWARE

Communication with the PC can be done either:-  
with the programs, we are distributing with our software tools shown in the next chapter or  
with your own GW-BASIC program.

Two example of GW programs are shown:

**Example 1**

This program shows the measured distances on the screen.

```

100 REM * DEMO1.BAS  GW-BASIC Program *
110 REM * ! Sensor is operating in continuous mode ! *
120 REM * Distances are recorded in a string *
130 ON ERROR GOTO 200
140 OPEN "COM1:9600,N,8,2" AS #1
150 WHILE INKEY$=""
160 IF NOT EOF(1) THEN LINE INPUT #1,C$:PRINT C$
170 WEND
180 CLOSE #1
190 END
200 IF ERR=57 THEN PRINT "Device Error": RESUME 150
210 IF ERR=69 THEN PRINT "Buffer Overflow":RESUME 150
220 STOP

```

**Example 2**

With this program the actual sensor setting is displayed on the screen. This program is written for the P42-A4N-2D-1.1-.... series.

```

10 REM STATUS.BAS
20 ON ERROR GOTO 350
30 DEF FNDEC(H$)=(ASC(LEFT$(H$,1))-48+(ASC(LEFT$(H$,1))>58)*7)*16+ASC(RI
GHT$(H$,1))-48+(ASC(RIGH T$(H$,1))>58)*7
40 CLS
50 PRINT,"*****"
60 PRINT,"*****      This program displays sensor settings      *****"
70 PRINT,"*****      of a P42-A4N-2D-1.1-xxxx      *****"
80 PRINT,"*****"
90 REM OPEN "COM1:9600,N,8,2" AS #1
100 OPEN "COM1:9600,N,8,2" AS #1
110 PRINT #1,"@#D"
120 T=TIMER+.3
130 IF TIMER < T GOTO 130
140 LINE INPUT #1,D$
150 PRINT
160 PRINT" Status of sensor: ";D$
170 PRINT
180 PRINT" Function", "Command", "Parameter"
190 PRINT"-----", "-----", "-----"
200 PRINT"Calibration slope  ", "@#Y",:PRINT USING"####"FNDEC(MID$(D$,2,2))
210 PRINT"Calibration offset  ", "@#X",:PRINT USING"####"FNDEC(MID$(D$,4,2))
220 PRINT"Mode register      ", "@#M",:PRINT USING"####"FNDEC(MID$(D$,7,2))
230 PRINT"Cycle time        ", "@#C",:PRINT USING"####"FIX(FNDEC(MID$(D$,9,2))/8)*8
240 PRINT"Under range       ", "@#U",:PRINT USING"####"FNDEC(MID$(D$,12,2))
250 PRINT"Addressode        ", "@#A",:PRINT USING"####"FNDEC(MID$(D$,14,2));:PRIN
T" => ";CHR$(FNDEC(MID$(D$,14,2)))
260 PRINT"Fail echo suppression", "@#T",:PRINT USING"####"FNDEC(MID$(D$,17,2))
270 PRINT"Over range counter ", "@#R",:PRINT USING"####"FNDEC(MID$(D$,19,2))
280 PRINT"Analogue offset   ", "@#O",:PRINT USING"####"FNDEC(MID$(D$,22,2))
290 PRINT"Analogue range     ", "@#S",:PRINT USING"####"FNDEC(MID$(D$,24,2))
300 PRINT"Hysteresis 1       ", "@#H",:PRINT USING"####"FNDEC(MID$(D$,27,2))
310 PRINT"Hysteresis 2       ", "@#G",:PRINT USING"####"FNDEC(MID$(D$,29,2))
320 PRINT"Set point 1         ", "@#1",:PRINT USING"####"FNDEC(MID$(D$,32,2))*256+
FNDEC(MID $(D$,34,2))
330 PRINT"Set point 2         ", "@#2",:PRINT USING"####"FNDEC(MID$(D$,37,2))*256+
FNDEC(MID $(D$,39,2))
340 END
350 IF ERR=57 THEN RESUME 150
360 IF ERR=24 THEN PRINT "No sensor connected"
370 PRINT "Error";ERR;" in Line ";ERL
380 STOP

```



## SOFTWARE TOOLS

(Stable up to Windows version WINXP, limited use with higher Windows versions  
Alternatively, terminal programs such as HTerm can be used.)

### UDSDEMO.EXE

UDSDEMO (COMPORT)

This program displays the actual measured distance on the screen. Pressing the <SPACE> bar changes the size of the characters.

Two programmes for supporting the programming of the sensors are available:  
UDS.EXE and SEND.EXE.

### UDSE.EXE

UDSE (COMPORT)

With this programme the sensor parameter can be set on-line. There is a direct access to the RAM of the sensor, so settings will change immediately. The adjustment can be done in an experimental way step by step.

Using the parameter COM2 or 2; COM 2 of the PC will be used. If the parameter is missing, COM 1 will be used. All other adjustments of the interface - baud rate, parity etc. - will be done by this programme.

On the first screen the programmable sensor can be selected by typing the corresponding number.

Then the programming screen appears.

The screen is divided in three windows:

- **input** window,
- **output** window and
- a window with a **list of commands**.(See picture)

Setting sensor into the 'HOLD' modus (connecting 'HLD' to GND) and pressing the space bar, a 4th window opens, displaying the **actual sensor settings** the sensor had at the moment the space bar was pressed. Whenever an update of these data is required, the space bar has to be pressed.

In the **input window** the commands sent to the sensor are displayed. If an error occurs during input please enter <CR> and repeat the correct command.

In the **output window**, the actual distance to the target is shown.

Example of the screen for programming the P42-M3A-2D-1G1-XXXX series:

```

***** PIL Sensoren GmbH ULTRASONIC DISTANCE SENSORS *****
***** P42-M3A-2D-1G1-XXXX *****

*Command INPUT*  DESCRIPTION  OF COMMANDS:
  @#S220          Comm          Function
  @#U100          @#UY          Dead zone 0<Y<255 in cm
  *Distance OUT * @#OY          Analogue Offset 0<Y<10000 in mm
  825             @#SY          Analogue Range 0<=Y<<10000 in mm
  825             @#1Y          Set point 1 0<Y<10000 in mm
  825             @#2Y          Set point 2 0<Y<10000 in mm
  825             @#RY          Over range counter 0<Y<255
  825             @#CY          Cycle. Time Y=64 64ms; 32 32ms; 16 16ms; 4 4ms
  825             @#W           Setting to EEPROM
  825             @#I           Load factory setting (220S) into RAM
  825             @#D           Display RAM Settings
  825             @#M           Mode Register (8 bit word)
  825             BIT          Val          Function (1)          Function (0)
  825             7            128         No Function
  825             6            64          Ser.data out RS232 disabled  -enabled
  825             5            32          No Function
  825             4            16          Negative Slope anal. out.  -positive
  825             3            8           Output without mean value  -with mean value
  825             2            4           Use for FM heads           -AM heads
  825             1            2           Switches set points in cm  -in mm
  825             0            1           Front panel disabled      -enabled
  
```

If the '>' button is pressed, the actual sensor setting will be written in a file named **STATUS.TXT** in the currently used directory. Sensor settings listed in this file can be transferred with the programme sende.exe into the sensor.

## SENDE.EXE

### SENDE (FILENAME)(COMPORT)

The easiest way of storing sensor settings is to write the commands in an ASCII file. This will be the best solution for applications, where many sensors have to be programmed with the same settings.

The programme SENDE.EXE will adjust the interface - baud rate, parity etc. -, the transfer of all commands to into the sensor.

Parameter 1 (FILENAME) has to be the name of the ASCII file containing the commands.

Parameter 2 (Comport) can be used optionally for COM2.

In this file **commands** have to be always in the begin of the line and start with '@'. One line for each command. Lines not beginning with '@' are treated as **comments**. Comments also can be added behind the command, separated by a 'TAB' or 'SPACE' sign.

## PROGRAMMING OF SENSORS WITH RS232 INTERFACE

Example:

ASCII file for adjustment P42- evaluation box to the P42-M0A-2D-1G1-300E

File name: '300E.UDS '

```
Programming evaluation unit to
Type P42-M3A-2D-1G1-300E
Sensor head: P42-A4M-2D-K300E
@#I      Load initial factory setting
@#U10    Under range 10cm
@#S1000  Analogue range 1000mm
@#C16    Cycle time 16ms
@#W      Write setting into EEPROM
```

This file will be transmitted to the sensor:

```
SENDE 300E.UDS      via COM1 or
SENDE 300E.UDS COM2 and
SENDE 300E.UDS 2   via COM2.
```

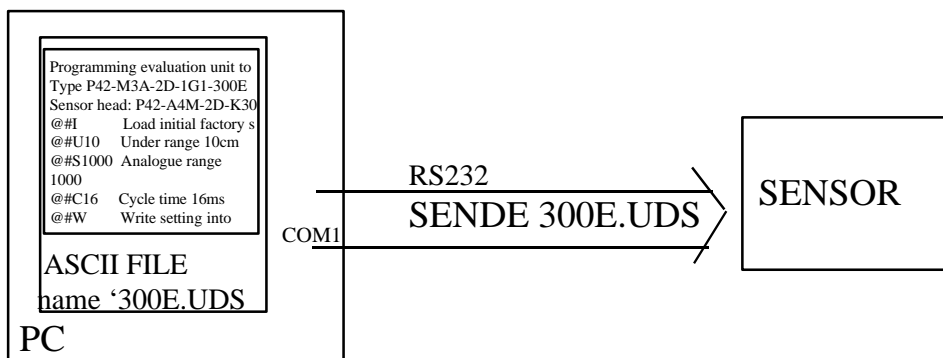

P42-M3A-2D-1G1-XXXX

**P42-M3A-2D-1G1-300E**

**P42-M3A-2D-1G1-180E**

**P42-M3A-2D-1G1-220S**

**P42-M3A-2D-1G1-130E**

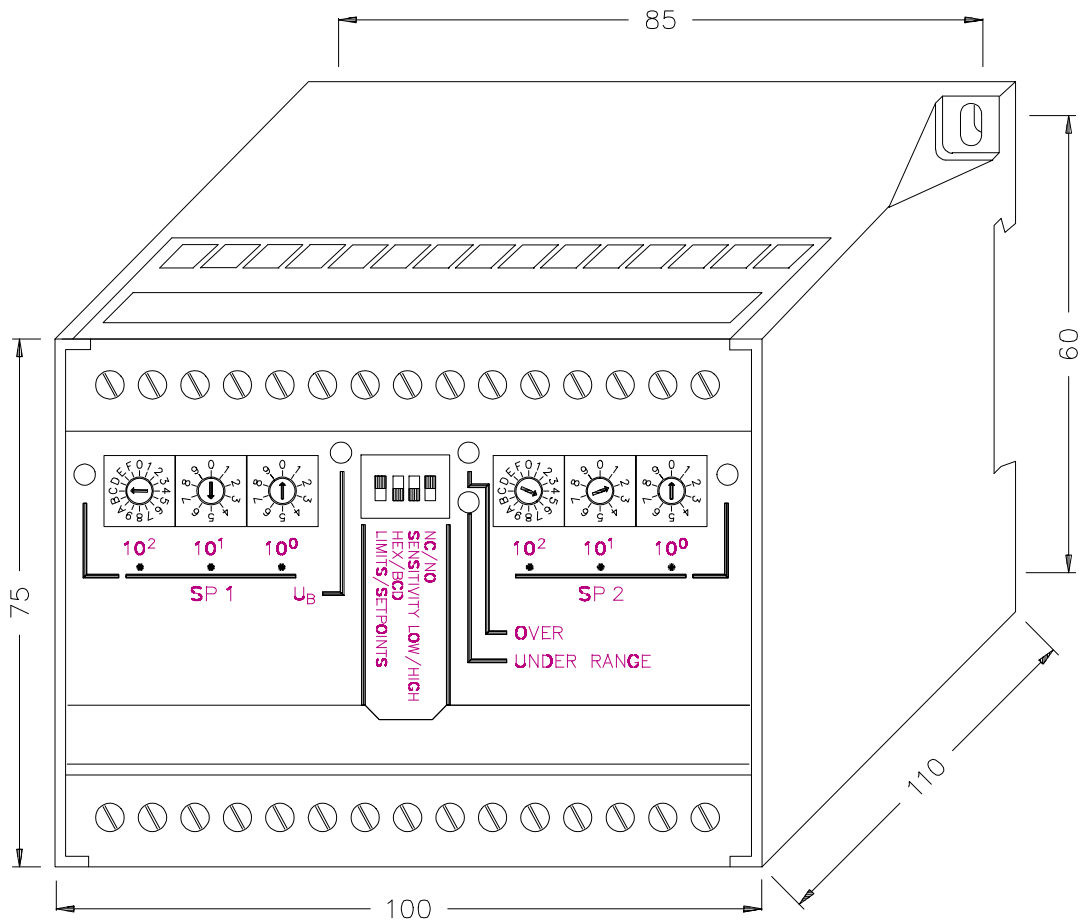

**P42-M3A-2D-1G1-300E**

**P42-M3A-2D-1G1-180E**

**P42-M3A-2D-1G1-220S**

**P42-M3A-2D-1G1-130E**

- \* PROGRAMMABLE
- \* ANALOGUE VOLTAGE AND CURRENT OUTPUT
- \* TWO ADJUSTABLE SWITCHING OUTPUTS
- \* SWITCHING OUTPUTS FOR OVER- AND UNDER-RANGE

**Listings:**

P42-M3A-2D-1G1-300E	including evaluation electronics P42-M0A-2D-1G1-300E sensor head P42-A4M-2D-K300E connector P66195074-001 + 1m cable	
P42-M3A-2D-1G1-220S	including evaluation electronics P42-M0A-2D-1G1-220S sensor head P42-A4M-2D-K220S connector P66195074-001 + 1m cable	
P42-M3A-2D-1G1-180E	including evaluation electronics P42-M0A-2D-1G1-180E sensor head P42-A4M-2D-K180E connector P66195074-001 + 1m cable	
P42-M3A-2D-1G1-130E	including evaluation electronics P42-M0A-2D-1G1-130E sensor head P42-A4M-2D-K130E connector P66195074-001 + 1m cable	
P42-A4M-2D-K300E	sensor head sealing IP67 100 to 900 mm	
P42-A4M-2D-K220S	standard sensor head 150 to 1500 mm	
P42-A4M-2D-K180E	sensor head sealing IP67 200 to 1500 mm	
P42-A4M-2D-K130E	sensor head sealing IP67 300 to 3000 mm	
P42-M0A-2D-1G1-130E/180E-220S/300E	evaluation electronics with PNP-switching outputs	
511741	standard connector	P66195074-001
513727	connector IP67	P66195075-001
512287	mounting clamp internal diameter for M30	P43178389-030
513552	beam deflector 90°, flat	P43192871-001
513705	beam deflector 90°, focusing	P43192871-002
512116	beam deflector plastic	P66195116-001
512383	programming cable	P55195101-101

## EVALUATION UNITS

These evaluation units can drive all P42 sensor heads. They have distance proportional voltage and current outputs, two fix and two adjustable switching outputs and a data output for a 4 digit digital display. Distance of a target is determined by the measuring time of flight of the ultrasonic pulse, temperature compensation and signal conditioning for suppressing of false echoes. Mean value routine can be used to achieve smooth analogue and stable switching outputs.

Distance information via nibble serial output can either be used to drive the digital display or be used directly in any control unit. With 4 switches function of the sensor can be selected. Via the RS232 interface the sensor can be adjusted to the application.

### Function switches

#### Switch 1: LIMITS\*/SETPOINTS

OFF Output is in the range of 0... 2000mm (programmable). Analogue output signal is in the range of 150 to 2000 mm.

ON Adjustable output characteristics:

1) Positive characteristic, when  $SP1 < SP2$ . SP1 defines the zero point, SP2 the final value.

2) Negative characteristic, when  $SP2 < SP1$ . SP2 defines the distance for min. output (final value).

#### Switch 2: HEX/BCD

OFF Multiplexed data output BCD code.

ON Multiplexed data output HEX code.

#### Switch 3: SENSITIVITY LOW / HIGH

OFF Receive sensitivity and beam angle are set to maximum.

ON Receive sensitivity and beam angle are set to minimum.

#### Switch 4: NC / NO

OFF Switching outputs 1 and 2 are normally open, i.e. they conduct when set point 1 (SP1) or set point 2 (SP2) is fallen below.

ON Switching outputs 1 and 2 are normally closed, i.e. inactive when set point 1 (SP1) or set point 2 (SP2) is fallen below.

#### \* Adjustment of analogue outputs with Function LIMITS (Switch 1 ON)

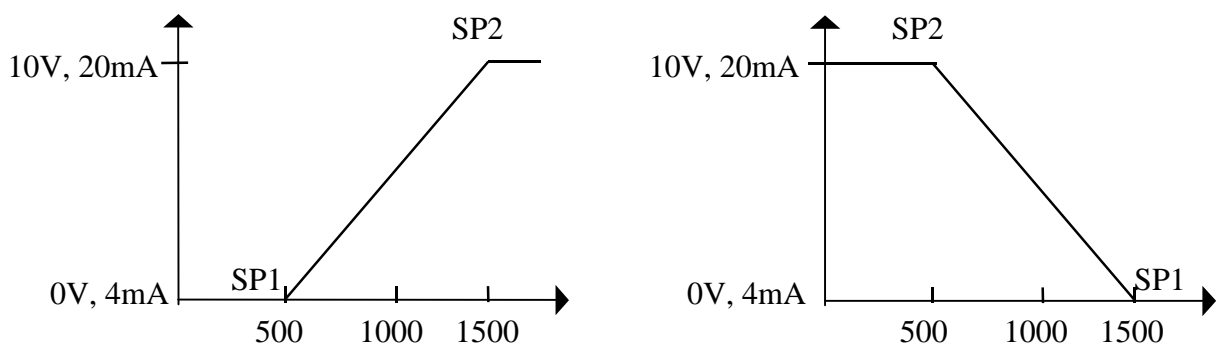

### Set point adjustment

Two mutually independent set points can each be adjusted with 3 digital switches one  $10^2 =$  hundreds switch, one  $10^1 =$  tens switch and one  $10^0 =$  units switch. Resolution is mm for evaluation units P42-M0A-2D-1G1-300E/220S/180E and cm for evaluation unit P42-M0A-2D-1G1-130E.

### Serial Interface RS 232

Serial Interface is fixed to data format 9600,N,8,2. Special software is not needed. Communication can be done with every terminal program.

### Technical Data

**Specifications** at 25°C typically

	-130E	180E	220S	300E
Max. Range mm	300...3000	200...2000	150 ...1500	100...900
Resolution mm			$\leq 1$	
Switching frequency Hz	5to8/prog	5to8/prog	5to8/prog	10to16/prog
Beam angle °	8	8	10	8
Carrier frequency kHz	130	180	220	300
Repeatability mm		1 mm , $\pm 0,2\%$ min		
Linearity		$\pm 0,3\%$ or 2mm		
Temperature compensation		0... 50°C		
Power supply	24V DC - stabilised (19...30V)			

### Switching outputs

PNP, 100mA, short circuit protected

SP1, SP2	adjustable independently in steps of 1mm (P42-M0A-2D-1G1-220S/180E/300E). Switching hysteresis is fixed to 1% of set point. Switching characteristic NO or NC can be selected.
ORA	No measurement can be made if the target is so distant from the sensor that the echo signal does not exceed the measuring threshold.
URA	Targets in this range are detected and signalled by the switching outputs. But as it is not possible to measure the position of a target under 150 mm(300 mm), no set point can be selected. Switching output URA (under range) conducts in this range.

### Hold/synchronising input

Connection /HLD with GND stops operating sensor. Last calculated distance is stored at the output. To avoid mutual interference from several sensors, these are very simply synchronised by interconnecting the HLD inputs. All synchronised sensors transmit at the same time.

### Multiplex digital outputs

BCD or HEX. 4-data bit and 4 decade-strobes NPN, open collector, 30V, 20mA, short circuit protected  
Time diagram of multiplex digital outputs see page 33.

### Analogue outputs

U	Voltage output 0 to 10V, $R_{lmin} = 1300R$
I	Current output 4. to 20mA, $R_{lmax} = 250R$

**Environmental conditions**

Operating temperature 0... 50°C  
 Storage temperature -25... +85°C  
 Sealing IP 40

**Housing** DIN-rail housing 100mm\*75mm\*110mm, 370g

**EMV** unit complies EMV test procedure according DIN EN 60947-5-2, Kategorie B, Schärfegrad 2.

**Wiring**

No.	Label.	Function
	<b>P W.S.</b>	External Power supply
1	24V	24V- supply voltage
2	GND	0V line
	<b>HEAD</b>	Sensor head terminals
3	24V	Supply voltage
4	GND	0V line
5	STA	Signal transmit command
6	STO	Stop signal, echo received
7	SEN	Receive sensitivity
8	TEM	Temperature sensor
	<b>RM. CO.</b>	Remote control
9	GND	0V- line
10	HLD	Transmit inhibit, synchronisation
	<b>OUTPUT</b>	Switching outputs
11	GND	0V-line
12	ORA	Over range, no echo
13	URA	Under range, target too close
14	SP 1	Switching output 1
15	SP 2	Switching output 2
	<b>ANALOG OUTPUT</b>	Analogue outputs
16	U	Voltage output 0 to 10V
17	GND	0V for voltage output
18	I	Current output 4 to 20mA
19	GND	0V for current output
	<b>PRG</b>	Asynchronous data line
20	TxD	Data out
21	GND	0V for asynchronous data line
22	RxD	Data in
	<b>DIGIT. OUTPUT</b>	Multiplexed digital outputs
23	10 <sup>3</sup>	1000 decade strobe
24	10 <sup>2</sup>	100 decade strobe
25	10 <sup>1</sup>	10 decade strobe
26	10 <sup>0</sup>	1 decade strobe
27	2 <sup>3</sup>	8 BCD/HEX
28	2 <sup>2</sup>	4 BCD/HEX
29	2 <sup>1</sup>	2 BCD/HEX
30	2 <sup>0</sup>	1 BCD/HEX



**Time diagram of multiplex digital outputs**

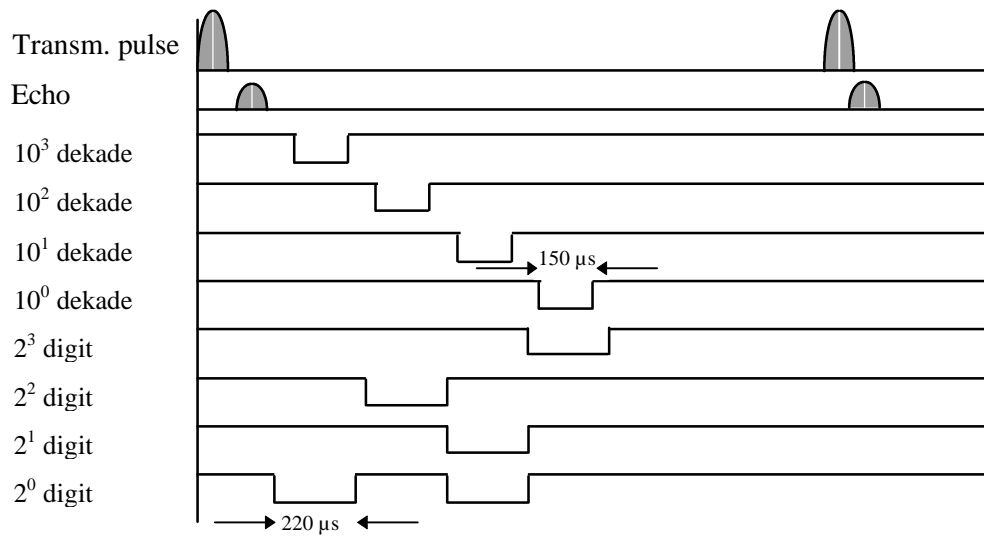

Actual output value is 1438.

**SENSOR HEADS**

P42-A4M-2D-K130, P42-A4M-2D-K220S, P42-A4M-2D-K180E , P42-A4M-2D-K300E

**Listing**

	Compatible with
P42-A4M-2D-K130E	P42-M0A-2D-1G1-130E P42-B0A/B-2D-1C/D1
P42-A4M-2D-K180E	P42-M0A-2D-1G1-180E P42-B0A/B-2D-1C/D1
P42-A4M-2D-K220S	P42-M0A-2D-1G1-220S P42-B0A/B-2D-1C/D1
P42-A4M-2D-K300E	P42-M0A-2D-1G1-300E P42-B0A/B-2D-1C/D1

**Technical Data**

	-130E	-180E	-220S	-300E
Max. sensing distance (mm)	3000	2000	1500	900
Min. sensing distance (mm)	400	200	150	100
Beam angle(°)	10	10	10	8
Carrier frequency (kHz)	130	220	180	300
Transmit/ receive mode			1	
Adjustment sensitivity				2
Temperature signal			3	
Measurement medium				Air
Temperature range (°C)		-15 to +70		
Storage temperature range (°C)		-15 to +80		
Sealing (IP)			65	
Sensor face	Epoxy	Epoxy	Silicone	Epoxy
Housing		Stainless steel		

**1 Transmit/receive mode key**

1 In case of a positive pulse at the STA-line the sensor starts transmitting. The echo comes as low active pulse at the STO-line.

**2 Adjustment sensitivity key**

The receive sensitivity can be adjusted at the SEN-Line either to high or reduced sensitivity.

**3 Temperature signal key**

The temperature signal at TEM is voltage calibrated in Kelvin, slope 10 mV/K. at 20°C the temperature voltage is 2.93V.

**Timing**

Pin 3 STA



Pin 4 STO

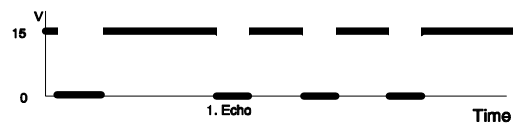

Pin 5 SEN

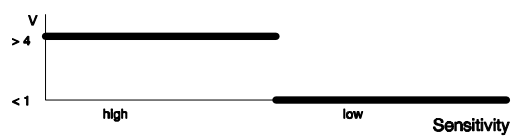

Pin 6 TEM

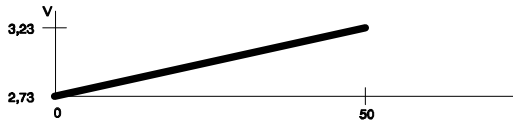

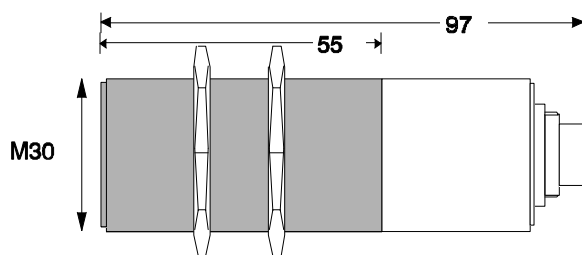

**Dimensions**

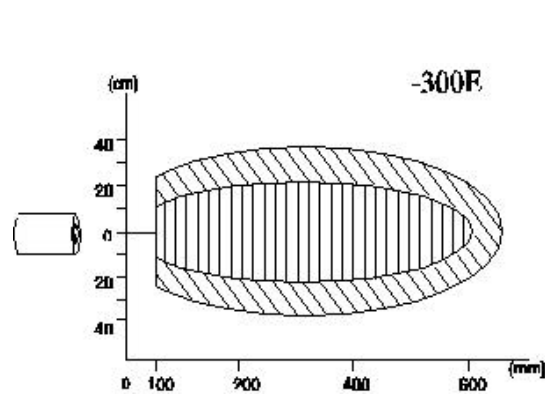
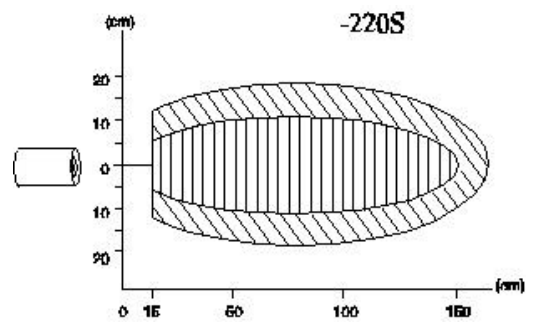
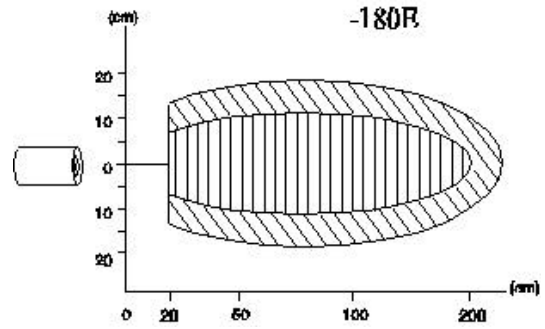
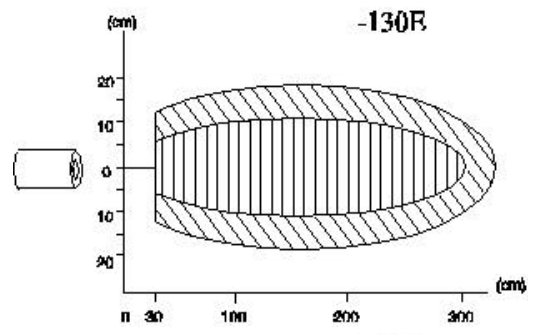

**Detection cones**



-  Guaranteed detection of a target 20x20 cm<sup>2</sup>
-  Possible detection of a large target

## PROGRAMMING THE P42-M3A-2D-1G1-XXXX SENSOR SERIES

### Structure of Memory Organisation

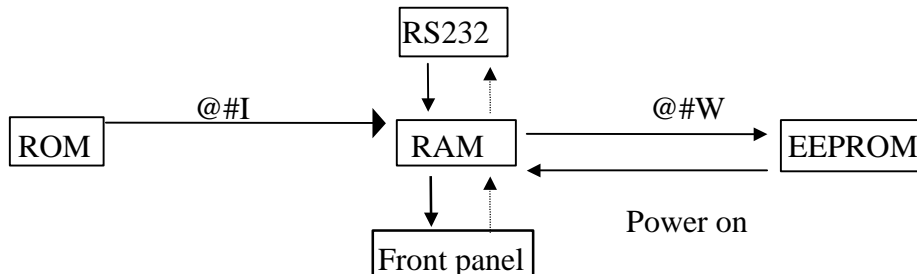

### Programming instruction

Baud rate set to 9600,N,8,2

Each command has the same structure: `@#Bp<CR>` with:

- @ Begin of command
- # Address of the sensor (set fix to '#')
- B Command always in capitals
- p Parameter, always dec. number in ASCII format
- <CR> End of command <CR>=ENTER=#13

A file containing only ASCII signs can be copied with the DOS command 'COPY file.ext COM1' via the interface into the evaluation electronics. As the sensor needs time for interpretation, the file may contain only one command. Time needed between different commands is around 1 ms. A more simple way to program the sensor is the use of the programs **UDSE.EXE** or **SENDE.EXE** available as accessories.

### List of Commands:

**Load factory setting into RAM** `@#I<CR>`

The initial setting will be written from the RAM into the ROM.

Factory settings added to the following commands are marked with a \*.

**Write actual setting into the EEPROM** `@#W<CR>`

The actual setting will be written into the EEPROM. The content of the EEPROM will be loaded into the RAM after connecting power to the sensor.

Adjustment of the **analogue output range** `@#Sp<CR>`  $0 \leq p \leq 10000$  mm `@#S2000*`

Output range is the range where the analogue output is changing between 0 to 10V or 4 to 20mA.

**Offset of the analogue output** `@#Op<CR>`  $0 \leq p \leq 10000$  mm `@#O0*`

Offset of the analogue sensor is the distance from the sensor head to the beginning of the analogue output range.

**Set point adjustments**

**Set point 1** @ #1p<CR> 0≤p≤10000 @ #1500\*  
**Set point 2** @ #2p<CR> 0≤p≤10000 @ #21500\*

Parameter defines the set point in mm. Hysteresis is fixed to 10mm if set points are programmed, otherwise hysteresis is 1% of selected steeping.

**Under range adjustment** @ #Up<CR> 0≤p≤255 @ #U15\*

Parameter p defines the dead zone of the sensor. Echoes from targets in this zone will be ignored.

**Cycle time adjustment** @ #Cp<CR> @ #C32\*

With the cycle time also the max. detection range is determined. Following values could be selected:

Command/ Cycle time/ max. range: @ #C64<CR> 64ms 10m; @ #C32<CR> 32ms 5m;  
 @ #C16<CR> 16ms 2.5m; @ #C8<CR> 8ms 1m; @ #C4<CR> 4ms 0.3m.

With the 3 LSBits size of the widow for the mean value calculation is adjusted. (Size= ±2<sup>x</sup>).

**Offset adjustment** @ #Xp<CR> 0≤p≤255 @ #X238\*

depends on sensor

There could be a difference between distance output and the real distance. 0<p<128 the offset is positive the 0 of the sensor is in front of the sensor face. 127<p<256 the offset is negative, the 0 of the sensor is behind the sensor face in the sensor. Negative offsets are adjusted the following way: Offset=-30 the sensor output is 30 mm too far -30+256=226 =>

@ #X226<CR>

**Over range counter** @ #Rp<CR> 0<p<256 @ #R30\*

Parameter p is the number of cycles where no echoes are received before the output of the sensor indicates the over range.

**Fail echo suppression counter**

**(Lock out Counter)** @ #Tp<CR> 0≤p≤255 @ #T4\*

Parameter p is the number of ignored echoes which are not in the expected window (see cycle time) window.

**Good echo counter (Lock in counter)** @ #Ep<CR> 0≤p≤255 @ #E3\*

This value should only be changed in accordance to the factory.

**Trigger** for single distance outputs #<CR>

If the sensor is in 'Hold mode' it can be triggered with '#' to send the distance of the following measurement via the RS232 interface.

**Read out sensor setting** @ #D<CR>

The status will be returned via RS232 from the sensor. Information of consist of 9 HEX words:

\$0000 \$0025 \$0F04 \$031F \$0000 \$07D0 \$01F4 \$03E8 \$050A

Corresponding commands: Y X M C U T E R O S 1 2 Hyst1,2

**Mode Register**

@#Mp<CR> 0≤p≤255

@#M1\*

Value of parameter p is between 0 and 255. It is determined by combination of following bits.

Name.	Bit	Value	Function ( 1 )	Function ( 0 )
	7	128		
SAO	6	64	Serial output disabled	Serial output enabled
	5	32		
INV	4	16	Negative slope analogue outputs	Positive slope
MWO	3	8	Output without mean value	With mean value
FM	2	4	Use of FM-sensor heads	Use of AM-sensor heads
CM	1	2	Switch in cm	Switch in mm
LOC	0	1	Front panel disabled	Front panel enabled

INV- Bit only for the programmed output ( O and S) which is active at Switch 1 position SET POINTS.

Example: @#M72

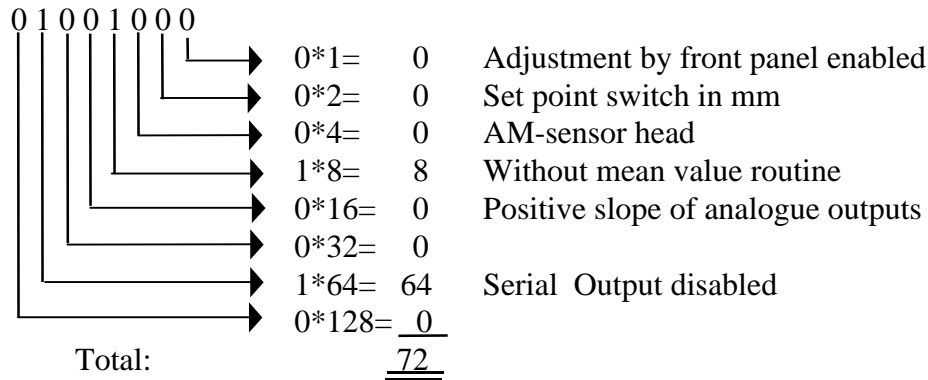

**Geometry**

**Settings**

Underrange (U)  
(cm)

Offset (O)  
(mm)

Range (S)  
(mm)

Setpoints (1 2)  
(mm)

**Outputs**

Digital RS232

Anlogue Voltage/Current

Switches SP1

SP2

Under range

Over range

**Status Indicators**

SW1 NO  
SW2 NO  
Under range  
Over range

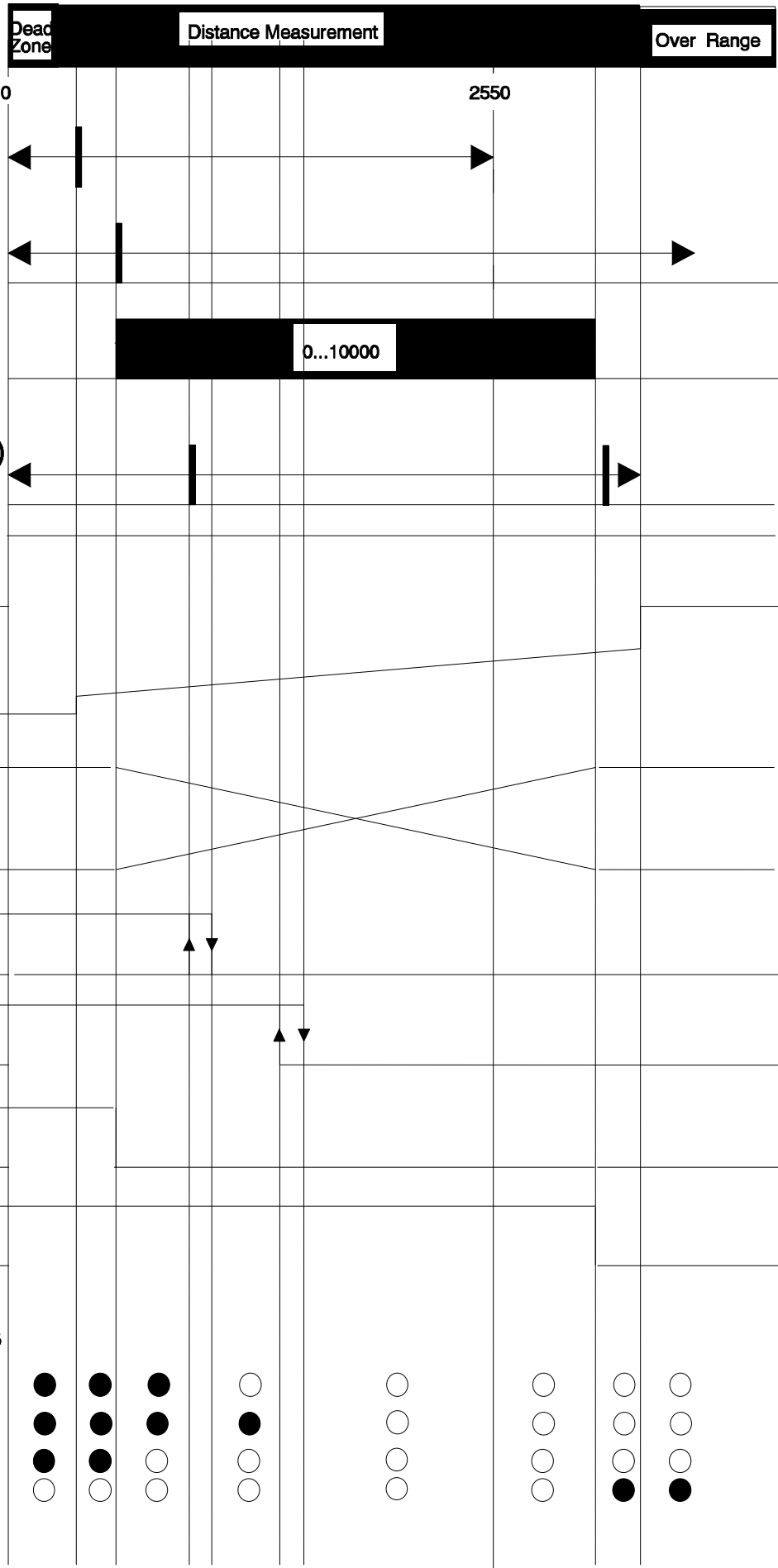

## EXAMPLES

### Winding / unwinding control

#### P42-M3A-2D-1G1-220S/180E

Diameter measurement of thin material.

Maximum coil diameter: 1.4 m.

Core diameter of coil : 0.2 m

Check if coil is in place.

Switch off if coil diameter is bigger than 10% of max. coil diameter.

Distance sensor - centre of coil: 1.1 m

0 V at minimum coil diameter

10 V at maximum coil diameter

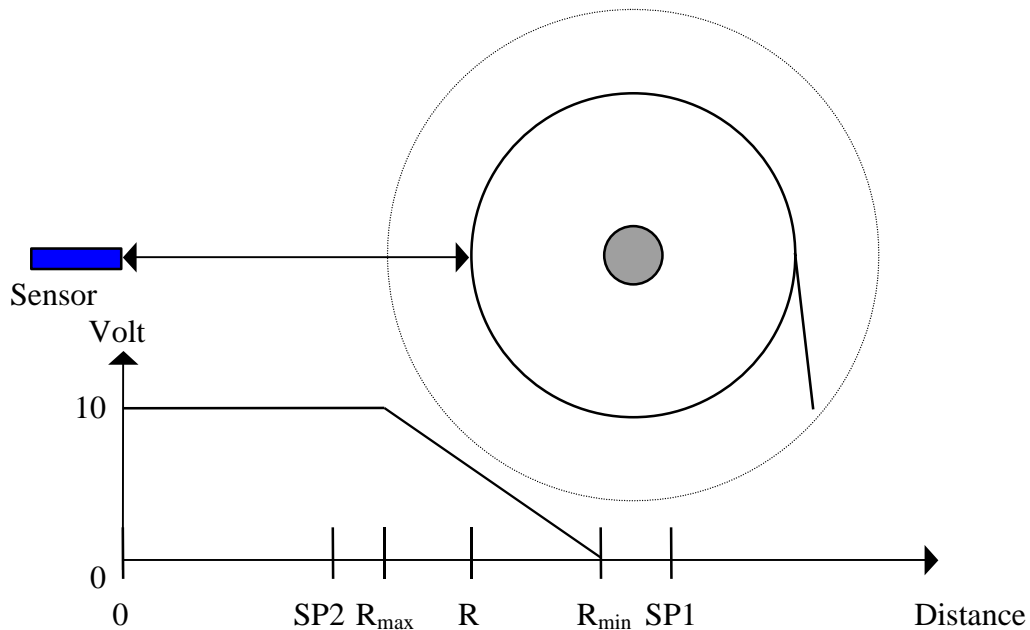

### Setting:

Mode register:

0 0 0 1 0 0 0 1

0	1*1=	1	Adjustment by front panel disabled
0	0*2=	0	Set point switch in mm
0	0*4=	0	AM-sensor head
1	0*8=	0	With mean value routine
0	1*16=	16	Negative slope of analogue outputs
0	0*32=	0	
0	0*64=	0	Serial Output enabled
1	0*128=	0	

Total: 17

@#M17<CR>

@#11200<CR>

@#2330<CR>

@#O400<CR>

@#S600<CR>

Check if coil is in place

Coil diameter bigger than 10% of max. diameter

Offset of analogue range

Range of analogue output

**Slope control**

**P42-M3A-2D-1G1-130E**

Stock of material before it enters pressing process.

Maximum slope 1800

Minimum slope 300

Alarm if no slope; material might be stretched.

Alarm if slope larger than maximum.

Distance sensor - Slope = 2.2 m.

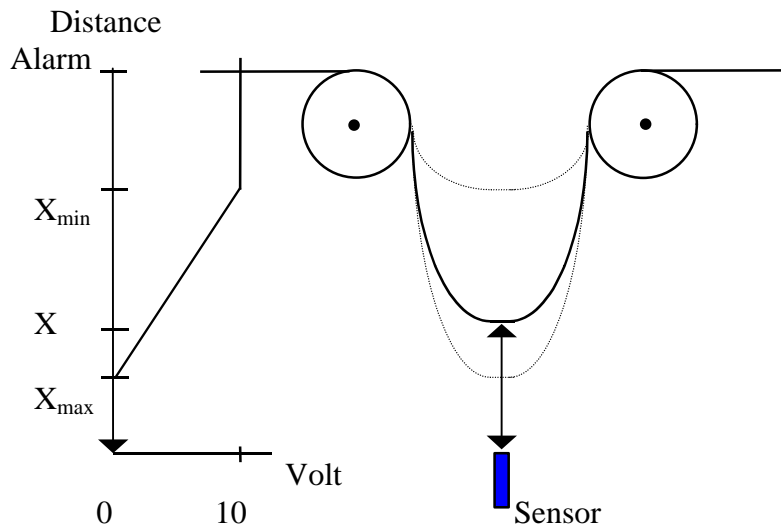

**Setting:**

Mode register:

0	0	0	0	0	0	0	0	1			
									1*1=	1	Adjustment by front panel disabled
									0*2=	0	Set point switch in mm
									0*4=	0	AM-sensor head
									0*8=	0	With mean value routine
									0*16=	0	Positive slope of analogue outputs
									0*32=	0	
									0*64=	0	Serial Output enabled
									0*128=	<u>0</u>	
Total:										<u><u>1</u></u>	

@#M1<CR>

@#12190<CR> Alarm „material might be stretched“ SP1 has to be set to NC at front panel. Hysteresis is fix 10 mm as setpoints are programmed.

@#2400<CR> Alarm slope too large. SP1 has to be set to NO at front panel.

@#O400<CR> Offset of analogue range.

@#S1500<CR> Analogue range.

@#R255<CR> Over range counter to maximum to suppress fail signals if slope is swinging and not all echoes are detected.



**Rapidly changing targets**

**P42-M3A-2D-1G1-300E**

Check of correct bottles by sorting of height.

Maximum height: 300 mm

Distance sensor conveyor: 450 mm

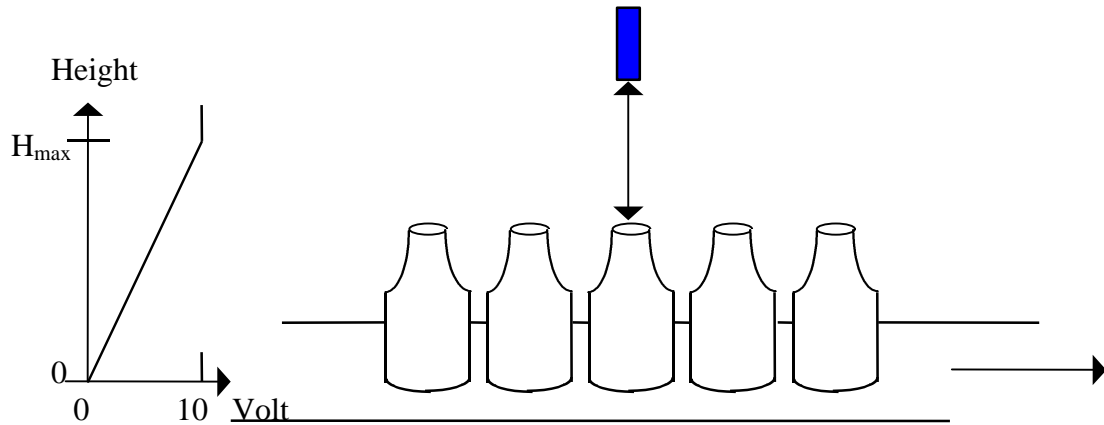

**Setting:**

Mode register:

0 1 0 0 0 1 0 1

0	1	0	0	0	1	0	1	1*1=	1	Adjustment by front panel disabled
								0*2=	0	Set point switch in mm
								0*4=	0	AM-sensor head
								1*8=	8	Without mean value routine
								1*16=	16	Negative slope of analogue outputs
								0*32=	0	
								1*64=	64	Serial Output disabled limits cycle time of sensor
								0*128=	<u>0</u>	
Total:									<u><u>89</u></u>	

@#M89<CR>

@#C4<CR>

@#O150

@#S300

Cycle time 4 ms

Offset of analogue range

Analogue range

P42-A4N-2D-1X1-XXXX

**P42-A4N-2D-1C1-220S/ 130E/ 300E**

**P42-A4N-2D-1D1-220S/ 130E**

**P42-A4N-2D-1E1-220S/ 130E**

**P42-A4N-2D-1F1-220S/ 130E**

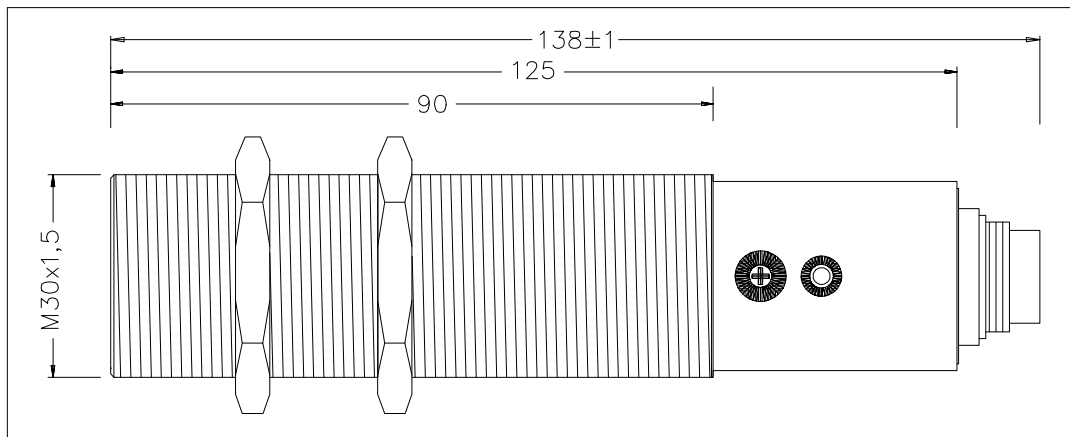

**P42-A4N-2D-1C1-220S/ 130E/ 300E**

**P42-A4N-2D-1D1-220S/ 130E**

**P42-A4N-2D-1E1-220S/ 130E**

**P42-A4N-2D-1F1-220S/ 130E**

- \* PROGRAMMABLE
- \* ANALOGUE AND SWITCHING OUTPUTS
- \* REPEATABILITY  $\pm 1$  MM

**Listings:**

All sensors are equipped with 2 programmable PNP switching outputs.  
Listing includes 8 pin connector : 66195126-001

Sensors with RS 232 interface:

Sensors with 0 to 10 V analogue output

	Analogue output	Sensing range in mm
P42-A4N-2D-1C1-130E	0 to 10 V	300 to 3000
P42-A4N-2D-1C1-220S	0 to 10 V	150 to 1500
P42-A4N-2D-1C1-300E	0 to 10 V	100 to 600

P42-A4N-2D-1D1-130E	4 to 20 mA	300 to 3000
P42-A4N-2D-1D1-220S	4 to 20 mA	150 to 1500

Sensors with RS 485 interface:

	Analogue output	Sensing range in mm
P42-A4N-2D-1E1-130E	0 to 10 V	300 to 3000
P42-A4N-2D-1E1-220S	0 to 10 V	150 to 1500
P42-A4N-2D-1F1-130E	4 to 20 mA	300 to 3000
P42-A4N-2D-1F1-220S	4 to 20 mA	150 to 1500

512396	Standard connector	P66195126-001
517336	Connector, angled with 2m cable	P55195126-001
512383	Program. scable with 1 sub min D9	P55195101-101
512377	RS232-RS485 interface	P55000003-002
512116	Compact beam deflector	P66195116-001
513552	Beam deflector	P43192871-001
513705	Focusing beam deflector	43192871-002
512287	Mounting clamp 30 mm	P43178389-030
512414	Mains filter	STV.2413.574.00262

**Technical Data**

Specifications at 25° typically

	-130E	-220S	300E
Max. Range mm	3000	1500	900
Min. Range mm	300	150	100
Beam angle(°)	10	10	8
Carrier frequency (kHz)	130	220	300
Temperature compensation (°C)	Yes	Yes	Yes
Interface	RS232 /RS485	RS232/RS485	RS232
Analogue output (mA)		4-20	
Repeatability (mm)		± 2 ±0.4%	
Response time (ms)		100	
Linearity (%)		± 0.5 / 3mm	
Output adjustment		Prog.	
Switching outputs		2 NO/ NC ; PNP	
Hysteresis (% of set point)		Prog.	
Switching frequency (Hz)		Prog. 5-30	
Output circuit		Open collector 100 mA	
Set point adjustment		Prog.	
Information output		Serial HEX/BCD	
Alignment LED		Yes	
Adjustable sensitivity		Potentiometer	
Control inputs		Hold/Synchronisation	
Temperature range (°C)		-15-+70	
Storage temperature range (°C)		-25-+85	
Supply voltage (V)		19-30	
Current consumption without load (mA)		<=25	
Circuit protection			
Reverse polarity on supply lines		Yes	
Voltage spikes on supply and output lines		Yes	
Short circuited switching output		Yes	
Sealing IP		65	
Housing		Stainless steel	

**Hold/synchronisation input**

If a measurement is only to take place in a certain instant, the sensor transmit and receive can be suppressed by a LOW (0V) at the hold HLD input. The last calculated distance is stored and output. During programming the HLD input should also be connected with the HLD line. If the sensor is enabled once more (HLD open or HIGH), a new output occurs after completion of a measurement cycle.

**Synchronisation**

To avoid mutual interference from several sensors, these are very simply synchronised by interconnecting the hold inputs.

### Detection cone

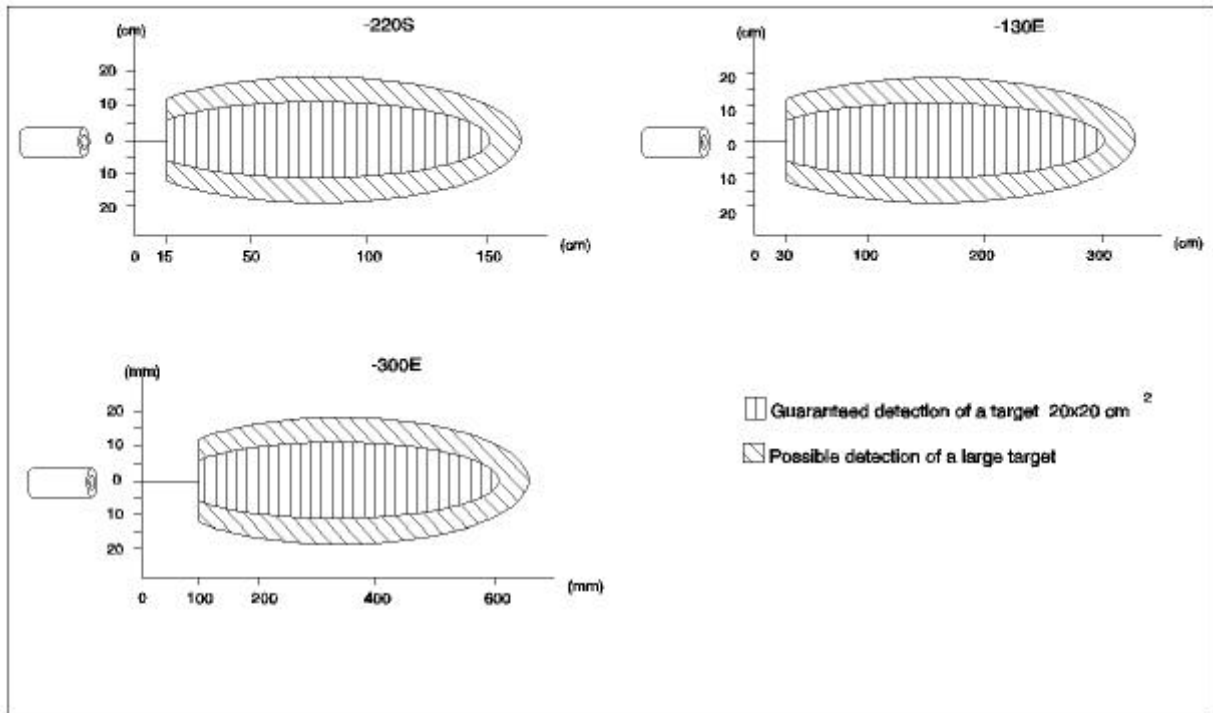

### Dimensions mm

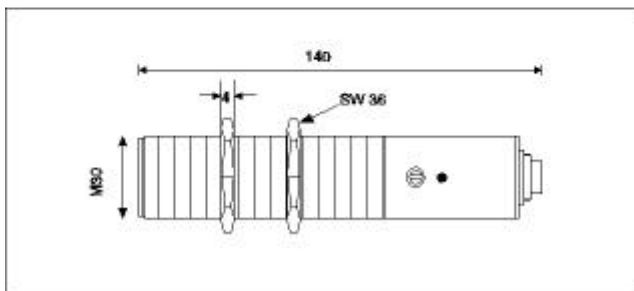

### Connector Pins

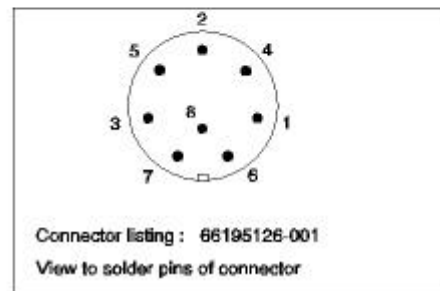

### Wiring

#### Pin Function

- 1 24 V= Supply
- 2 0 V GND
- 3 Analogue Output; 0 to 10 V
- 4 Switching output 1 (PNP)
- 5 Switching output 2 (PNP)
- 6 Transmit inhibit;/ Synchronisation HLD
- 7 RS232 RxD or RS485-B
- 8 RS232 TxD or RS485-A

### Wiring Diagram

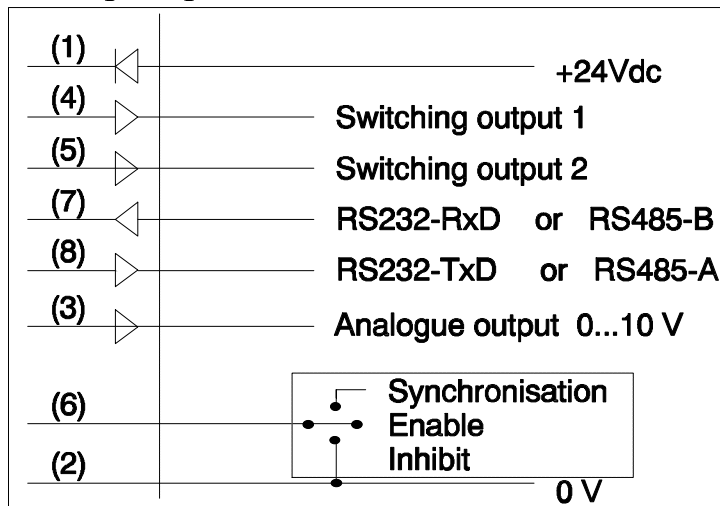

## PROGRAMMING THE P42-A4N-2D-1C/D/E/F1-XXXX SENSOR SERIES

### Structure of Memory Organisation

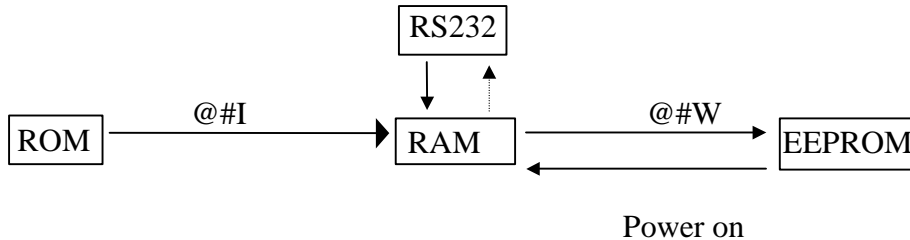

### Programming instruction

During programming connect HLD (6) with GND (2).

Set baudrate fix to 9600,N,8,2 (no parity bit, 8 data bits and 2 stop bits).

### Structure of commands

Each command has the same structure: @aBp<CR>

- @ Beginning of command, always identical
- a Address of sensor; with '#' all sensors will be addressed
- B Command
- p Parameter
- <CR> End of command CR=ENTER=#13

A file containing only ASCII signs can be copied with the DOS command 'COPY file.ext COM1' via the interface into the evaluation electronics. As the sensor needs time for interpretation, the file may contain only one command. Time needed between different commands is around 1 ms. A more simple way to program the sensor is the use of the programs **UDSE.EXE** or **SENDE.EXE** available as accessories.

### List of Commands:

**Load factory setting** into RAM @#I<CR>

The initial setting will be written from the EEPROM into the ROM. Factory settings added to the following commands are marked with a \*.

**Write actual setting** into the EEPROM @#W<CR>

The actual setting will be written into the EEPROM. The content of the EEPROM will be loaded into the RAM after connecting power to the sensor.

**Change sensor address from A to ASC(Y)** @aAp<CR> p see list page 9 @aA97\*  
ASC(97) = a

**Adjustment of the analogue output range @aSp<CR> 0≤p≤255 cm @aS200\***

Output range is the range where the analogue output is changing between 0 to 10V. An analogue output range of 200 means that within 200 cm the analogue output value changes from 0 to 10V or 4 to 20 mA.

**Offset of the analogue output @aOp<CR> 0≤p≤255 cm @aO0\***

Offset of the analogue sensor is the distance from the sensor head to the beginning of the analogue output range. With an offset of 50 the analogue range begins 50 cm in front of the sensor. With normal slope of the output it starts with the lowest analogue value (0 V or 4 mA) and with inverted slope with the highest analogue value (10 V or 20 mA).

**Switching output adjustments**

**Set point 1 @a1p<CR> 0≤p≤10000 mm @a500\***

**Set point 2 @a2p<CR> 0≤p≤10000 mm @a1000\***

**Hysteresis adjustments of the switching outputs**

**Hysteresis set point 1 @aHp<CR> 0≤p≤255 mm @aH10**

**Hysteresis set point 2 @aGp<CR> 0≤p≤255 mm @aG10**

**Under range adjustment @aUp<CR> 0≤p≤255 @aU15\***

Parameter p defines the dead zone of the sensor. Echoes from targets in this zone will be ignored.

**Cycle time adjustment @aCp<CR> @aC32\***

With the cycle time also the max. detection range is determined. Following values could be selected:

Command/ Cycle time/ max. range: @aC64<CR> 64ms 10m; @aC32<CR> 32ms 5m;

@aC16<CR> 16ms 2.5m; @aC8<CR> 8ms 1m; @aC4<CR> 4ms 0.3m.

With the 3 LSBits size of the widow for the mean value calculation is adjusted. (Size= ±2<sup>x</sup> ).

**Offset adjustment @aXp<CR> 0≤p≤255 @aX238\***

depends on sensor

There could be a difference between distance output and the real distance. 0<p<128 the offset is positive the 0 of the sensor is in front of the sensor face. 127<p<256 the offset is negative, the 0 of the sensor is behind the sensor face in the sensor. Negative offsets are adjusted the following way: Offset=-30 the sensor output is 30 mm too far -30+256=226 =>

@aX226<CR>

**Over range counter @aRp<CR> 0<p<256 @aR30\***

Parameter p is the number of cycles where no echoes are received before the output of the sensor indicates the over range.

**Fail echo suppression counter @aTp<CR> 0≤p≤255 @aT52\***

Upper 4 bits of parameter is the setting for the Lock-In Counter and lower 4 bits is the setting for the Lock Out Counter. Factory setting p=34, 34 HEX corresponds to 52 BCD.

**Read out sensor setting @aD<CR>**

The status will be returned via RS232 from the sensor. Information of consist of 8 HEX words:

\$\*\*\*\* \$0125 \$0F61 \$341E \$00C8 \$0A14 \$01F4 \$03E8

Corresponding commands: Y X M C U A T R O S Hyst1,2 1 2  
(See detailed listing next page)

**Read out of one Distance Measurement a<CR>**

If sensor is HOLD-mode (HLD connected with GND) this command allows to take only one read out of a distance measurement. If during this measurement fail echo supression is done, the measurement is repeated until a valid value is on the output. Instead using the sensor address a, # can also be used.

**Mode Register @aMp<CR> 0≤p≤255 @aM1\***

Value of parameter p is between 0 and 255. It is determined by combination of following bits.

Name.	Bit	Value	Function ( 1 )	Function ( 0 )
SET	7	128	Range detection switching outputs	Normal switching function
SAO	6	64	Serial output disabled	Serial output enabled
HFT*	5	32	Special triggering of Echo	Normal triggering
INV	4	16	Negative slope analogue outputs	Positive slope
MWO	3	8	Output without mean value	With mean value
NC2	2	4	Switch 2 is NC	Switch 2 is NO
NC1	1	2	Switch 1 is NC	Switch 1 is NO
BCD	0	1	Digital output in BCD	Digital output in HEX

\* HFT bit is recommended to be set to 0

Example:

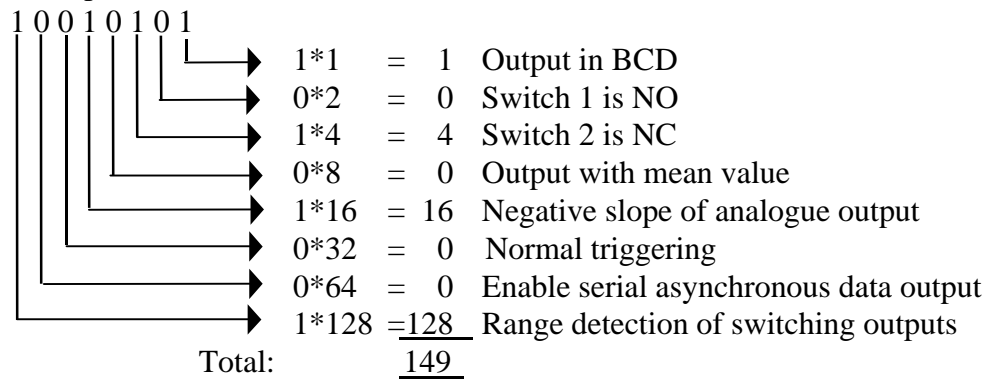

Command for mode register: @aM149<CR>



**Read out actual sensor settings**

Output	Factory Setting		Description
	HEX	BCD	
\$1A1B			Word 1
1A1B	**	**	Factory setting
\$2A2B			Word 2
2A	01	01	Mode register
2B	25	37	Cycle time
\$3A3B			Word 3
3A	0F	15	Under range setting (cm)
3B	61	97	Address of sensor "a"
\$4A4C			Word 4
4A	34	52	Factory setting
4C	1E	30	Over range counter
\$5A5B			Word 5
5A	0	0	Offset of analogue range
5B	C8	200	Analogue output range (cm)
\$6A6B			Word 6
6A	0A	10	Hysteresis set point 1 (mm)
6B	14	20	Hysteresis set point 2 (mm)
\$7AAA			Word 7
7AAA	1F4	500	Set point 1 (cm)
\$8AAA			Word 8
8AAA	3E8	1000	Set point 2 (cm)

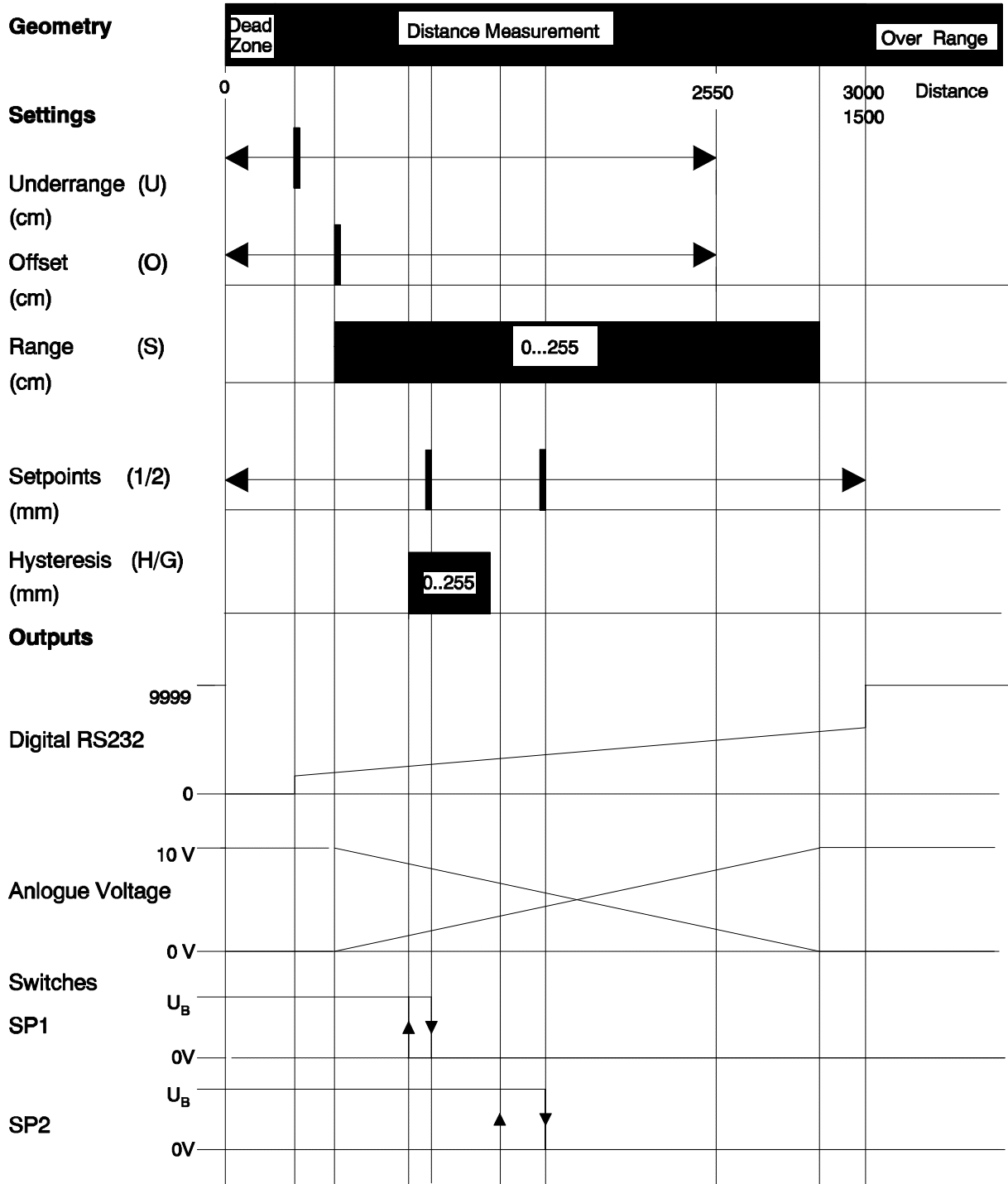

## Examples

### **Winding / unwinding control**

#### **P42-A4N-2D-1C1-220S**

Diameter measurement of thin material.

Maximum coil diameter: 1.4 m.

Core diameter of coil : 0.2 m

Check if coil is in place.

Switch off if coil diameter is bigger than 10% of max. coil diameter.

Distance sensor - centre of coil: 1.1 m

0 V at minimum coil diameter

10 V at maximum coil diameter

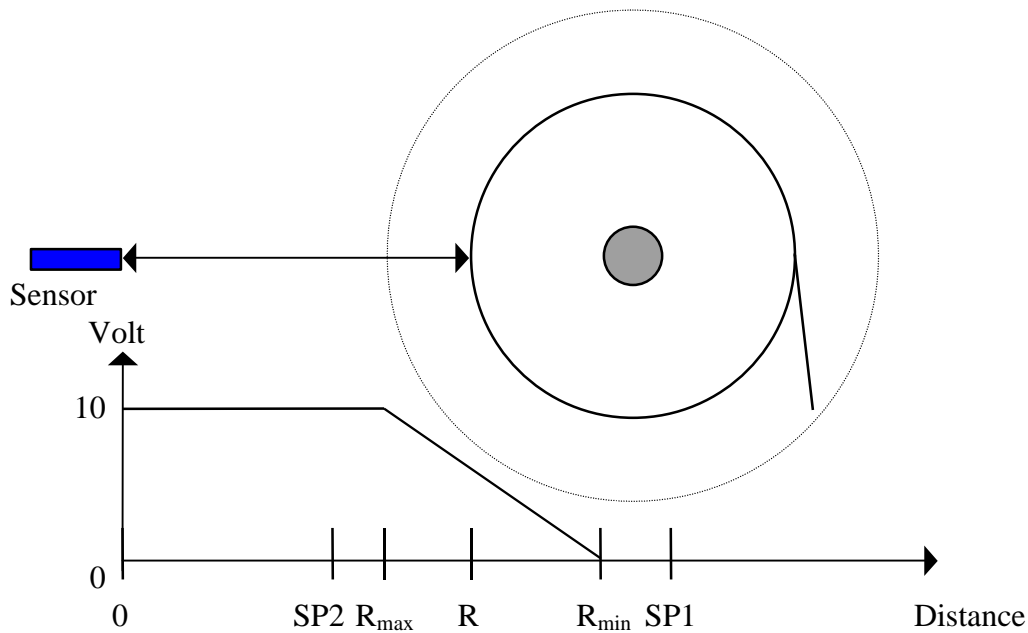

### **Setting:**

Mode register:

0	0	0	1	0	0	0	1			
								1*1=	1	Output in BCD
								0*2=	0	Switch 1 is NO
								0*4=	0	Switch 2 is NO
								0*8=	0	With mean value routine
								1*16=	16	Negative slope of analogue outputs
								0*32=	0	Normal triggering
								0*64=	0	Serial output enabled
								0*128=	0	Normal switching function
Total:									<u>17</u>	

@aM17<CR>

@a11200<CR>

@a2330<CR>

@aO400<CR>

@aS600<CR>

Check if coil is in place

Coil diameter bigger than 10% of max. diameter

Offset of analogue range

Range of analogue output

**Slope control**

**P42-A4N-2D-1C1-220S**

Stock of material before it enters pressing process.

Maximum slope 1800

Minimum slope 300

Alarm if no slope; material might be stretched.

Alarm if slope larger than maximum.

Distance sensor - Slope = 2.2 m.

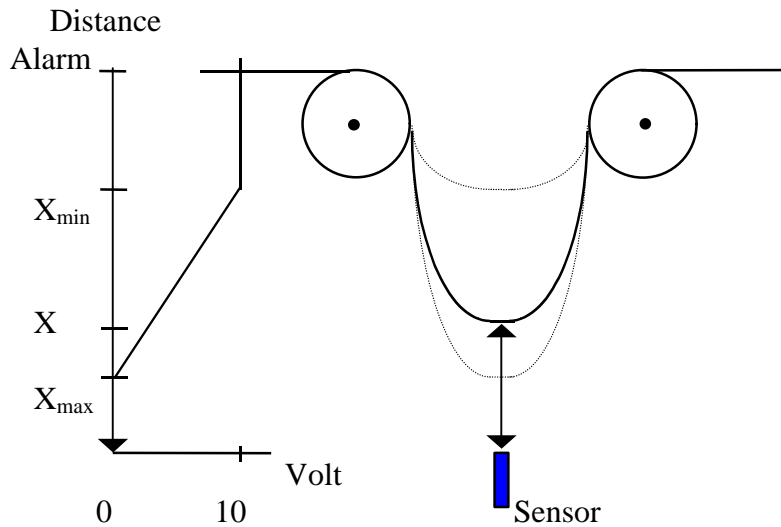

**Setting:**

Mode register:

0 0 0 0 0 0 1 1

- 1\*1= 1 Output in BCD
- 1\*2= 2 Switch 1 is NC
- 0\*4= 0 Switch 2 is NO
- 0\*8= 0 With mean value routine
- 0\*16= 0 Positive slope of analogue outputs
- 0\*32= 0 Normal triggering
- 0\*64= 0 Serial Output enabled
- 0\*128= 0 Normal switching function

Total: 3

@#M1<CR>

@#12200<CR> Alarm „material might be stretched“ SP1.

@#H0<CR> Hysteresis set point 1 = 0 mm.

@#2400<CR> Alarm slope too large.

@#G10<CR> Hysteresis set point 2 = 10 mm.

@#O400<CR> Offset of analogue range.

@#S1500<CR> Analogue range.

@#R255<CR> Over range counter to maximum to suppress fail signals if slope is swinging and not all echoes are detected.

**Rapidly changing targets**  
**P42-A4N-2D-1C1-220S**

Check of correct bottles by sorting of height.

- Correct bottle height: 250 mm
- Maximum height: 300 mm
- Distance sensor conveyor: 450 mm
- Following switching output information desired:
- Bottle too high: height 255 to 350 mm
- Bottle too small: height 5 to 245 mm
- Correct bottle: height 245 to 255 mm

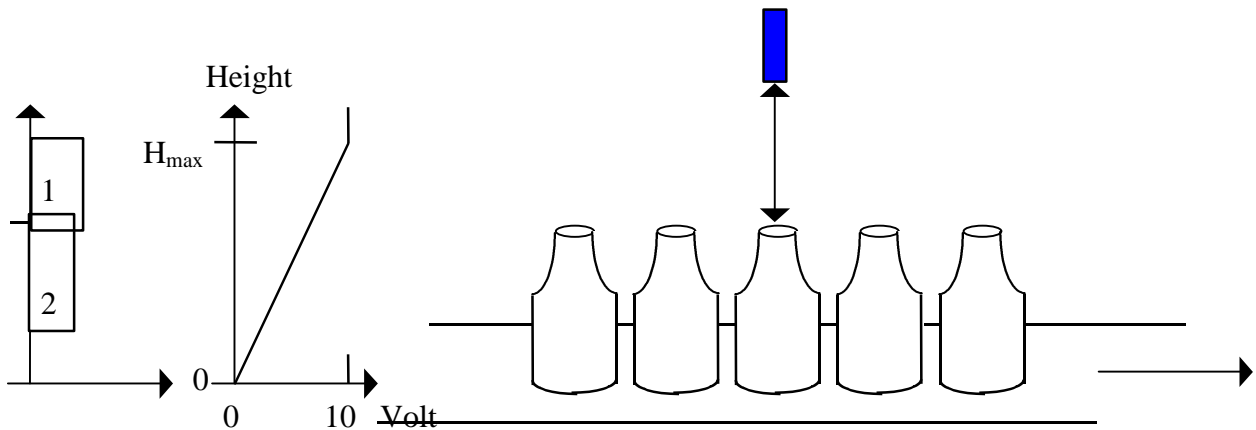

**Setting:**

Mode register:

1	1	0	1	1	0	0	1								
								→	1*1	=	1	Output in BCD			
								→	0*2	=	0	Switch 1 is NO			
								→	0*4	=	0	Switch 2 is NO			
								→	1*8	=	8	Output with mean value			
								→	1*16	=	16	Negative slope of analogue output			
								→	0*32	=	0	Normal triggering			
								→	1*64	=	64	Disable serial asynchronous data output			
								→	1*128	=	128	Range detection of switching outputs			
Total:											<u>217</u>				

- @aM217<CR>
- @aC4<CR>            Cycle time 4 ms
- @aO150<CR>        Offset of analogue range
- @aS300<CR>        Analogue range
- @a1100<CR>        Set point 1 at 100 mm
- @aH105<CR>        Hysteresis set point 1 = 95 mm. Switching output 1 switches if top of the bottle is in range 1.
- @a2195<CR>        Set point 2 at 195 mm.
- @aG250<CR>        Hysteresis set point 2 = 250 mm. Switching output 2 switches if top of the bottle is in range 2.

	Switching output 1	Switching output 2
Bottle too high:	ON	OFF
Bottle too small:	OFF	ON
Bottle correct height:	ON	ON

INDEX	Page
<CR>	9
@a1p<CR>	14
@a2p<CR>	14
@aAp<CR>	11
@aCp<CR>	11
@aCp<CR>	21
@aD<CR>	10
@aEp<CR>	20
@aGp<CR>	14
@aHp<CR>	14
@aI<CR>	10
@aMp<CR>	15
@aO<CR>	15
@aRp<CR>	17
@aSp<CR>	15
@aTp<CR>	20
@aUp<CR>	12
@aW<CR>	10
@aXp<CR>	17
55000003-002	8
55000005-002	6
Actual sensor settings	25
Actual setting into EEPROM	10
Adapter	6
address of sensor	9
Address of sensor	11
Analogue output	15
Analogue output, offset	15
Analogue output, range	15
ASCII table	11
baud rate	5
BCD - HEX conversion list	22
Change sensor address	11
Commands	9
Commands	10
Connection sensor-PC	5
Conversion list BCD - HEX	22
Converter RS232-RS485	8
Counter lock in	19
Counter lock in	20
Counter lock out	19
Counter lock out	20
Counter over range	17
Cycle time	11
Cycle time	21
Dead zone	12
EEPROM	4
End of command	9

Factory setting into RAM	10
Fail pulse suppression	19
Front panel	4
GW-BASIC program	23
GW-BASIC program	24
Hardware	5
Hardware set-up	5
hold' mode	5
Hysteresis	14
Input window	25
List of commands window	25
Load factory setting into RAM	10
Lock in counter	19
Lock in counter	20
Lock out counter	19
Lock out counter	20
Lowest significant bit	16
LSB	16
Maximum distance	12
Measurement principle	11
Measurement window	21
Memory organisation	4
Mode register	15
Most significant bit	16
MSB	16
Offset	15
Offset of analogue output	15
Organisation memory	4
Output window	25
Over range counter	17
parity	5
Principle of measurement	11
Programming adapter	6
RAM	4
Range	15
Range of anaolgue output	15
Read out sensor setting	10
ROM	4
RS232	4
RS232-RS485	8
RS232-RS485 converter	8
SENDE.EXE	26
Sensor address	11
Sensor offset	17
Sensor setting read out	10
Sensor settings into file	26
Sensor settings, actual	25
Sensor-PC	5
Set point adjustment	14
Set-up hardware	5

Software	23
Software tools	25
Speed of window	21
Start of command	9
STATUS.TXT	26
stop bits	5
Structure of commands	9
Structure of memory organisation	4
Suppression of fail pulses	19
Switching window	14
Tools, software	25
UDSD.EXE	25
UDSDEMO.EXE	25
UDSE.EXE	25
UDSF.EXE	25
Under range	12
Under range adjustment	12
Window, input	25
Window, list of commands	25
Window, measurement	21
Window, output	25
Window, speed	21
Write actual setting into EEPROM	10
P42-A4N-2D-1C1-130E	42
P42-A4N-2D-1C1-220S	
P42-A4N-2D-1C1-300E	
P42-A4N-2D-1D1-130E	
P42-A4N-2D-1D1-220S	
P42-A4N-2D-1E1-130E	
P42-A4N-2D-1E1-220S	
P42-A4N-2D-1F1-130E	
P42-A4N-2D-1F1-220S	
P42-A4N-2D-1....	
@a1p<CR>	47
@a2p<CR>	47
@aAp<CR>	46
@aCp<CR>	47
@aD<CR>	48
@aGp<CR>	47
@aHp<CR>	47
@aI<CR>	46
@aMp<CR>	48
@aO<CR>	47
@aRp<CR>	47
@aSp<CR>	47
@aTp<CR>	47
@aUp<CR>	47
@aW<CR>	46
@aXp<CR>	47
a<CR>	48



Actual setting into EEPROM	46
Address of sensor	46
Analogue output	47
Analogue output, offset	47
Analogue output, range	47
P42-A4N-2D-1....	
Change address of sensor	46
Commands	46
Counter over range	47
Cycle time	47
Detection cone	45
Dimensions	45
Examples	51
Factory setting into RAM	46
Fail pulse suppression	47
Geometry	50
Hold/synchronising input	44
Hysteresis	47
List of commands	46
Listings	43
Load factory setting into RAM	46
Memory organisation	46
Mode register	48
Offset of analogue output	47
Over range counter	47
Programming	46
Programming instruction	46
Range	47
Range of analogue output	47
Read out sensor setting	48
Sensor offset	47
Sensor setting read out	48
Set point adjustment	47
Structure of commands	46
Suppression of fail pulses	47
Synchronisation	44
Technical data	44
Trigger for one distance output	48
Under range	47
Under range adjustment	47
Wiring	45
Write actual setting into EEPROM	46



P42-M3A-2D-1G1-130E	28
P42-M3A-2D-1G1-180E	
P42-M3A-2D-1G1-220S	
P42-M3A-2D-1G1-300E	
P42-M3A-2D-1G1-...	
#<CR>	36
@#1p<CR>	36
@#2p<CR>	36
@#Cp<CR>	36
@#D<CR>	36
@#Ep<CR>	36
@#I<CR>	35
@#Mp<CR>	37
@#O<CR>	35
@#Rp<CR>	36
@#Sp<CR>	35
@#Tp<CR>	36
@#Up<CR>	36
@#W<CR>	35
@#Xp<CR>	36
Actual setting into EEPROM	35
Address of sensor	35
Analogue output	35
Analogue output, offset	35
Analogue output, range	35
Analogue outputs	31
Commands	35
Counter lock in	36
Counter lock in	36
Counter lock out	36
Counter lock out	36
Counter over range	36
Cycle time	36
Evaluation units	30

Examples	39
Factory setting into RAM	35
Fail pulse suppression	36
Function switches	30
Geometry	38
Hold/synchronising input	31
List of commands	35
Listings	29
Load factory setting into RAM	35
Lock in counter	36
Lock in counter	36
P42-M3A-2D-1G1-...	
Lock out counter	36
Lock out counter	36
Memory organisation	35
Mode register	37
Multiplex digital output	31
Multiplex digital output, time diagram	33
Offset of analogue output	35
Over range counter	36
Programming	35
Programming instruction	35
Range	35
Range of analogue output	35
Read out sensor setting	36
RS 232	31
Sensor heads	33
Sensor offset	36
Sensor setting read out	36
Serial interface	31
Set point adjustment	31
Set point adjustment	36
Structure of commands	35
Suppression of fail pulses	36
Switching outputs	31
Technical data	31
Time diagram of multiplex digital output	33
Trigger for one distance output	36
Under range	36
Under range adjustment	36
Wiring	32
Write actual setting into EEPROM	35

## Cross-reference list PiL (old) / Honeywell

Historic nomenclature *	Current nomenclature	Order No.
P42-A4Y-2D-1D1-S273	P42-150-M30-I2P-RS232	515214
P42-A4Y-2D-1E1-S273	P42-150-M30-U2P-RS485	515215
P42-A4N-2D-1F1-220S	P42-150-M30-ST-I2P-RS485-C723	512217
P42-A4N-2D-1F1-180E	P42-200-M30-ST-I2P-RS485-C723	516273
P42-A4N-2D-1F1-130E	P42-300-M30-ST-I2P-RS485-C723	512216
P42-A4N-2D-1E1-220S	P42-150-M30-ST-U2P-RS485-C723	512214
P42-A4N-2D-1E1-130E	P42-300-M30-ST-U2P-RS485-C723	512213
P42-A4N-2D-1D2-130E	P42-300-M30-ST-I2N-RS232-C723	514704
P42-A4N-2D-1D1-300EPC	P42-60-M30-STc-I2P-RS232-C723	516505
P42-A4N-2D-1D1-300E	P42-60-M30-ST-I2P-RS232-C723	512212
P42-A4N-2D-1D1-220S	P42-150-M30-ST-I2P-RS232-C723	512211
P42-A4N-2D-1D1-180E	P42-200-M30-ST-I2P-RS232-C723	512210
P42-A4N-2D-1D1-130E	P42-300-M30-ST-I2P-RS232-C723	512209
P42-A4N-2D-1C1-300E	P42-60-M30-ST-U2P-RS232-C723	512208
P42-A4N-2D-1C1-220S	P42-150-M30-ST-U2P-RS232-C723	512207
P42-A4N-2D-1C1-180E	P42-200-M30-ST-U2P-RS232-C723	512206
P42-A4N-2D-1C1-130E	P42-300-M30-ST-U2P-RS232-C723	512205
P42-A4Y-2D-1F1-S273	P42-150-M30-I2P-RS485-2m	515216
P42-M0A-2D-1G1-65E	P42-800-BOX-UI2P-RS232	513828
P42-M0A-2D-1G1-300E	P42-90-BOX-UI2P-RS232	512254
P42-M0A-2D-1G1-200E	P42-150-BOX-UI2P-RS232	513923
P42-M0A-2D-1G1-180E	P42-250-BOX-UI2P-RS232	512252
P42-M0A-2D-1G1-130E	P42-400-BOX-UI2P-RS232	512250
P42-M0A-2D-1G1	P42-BOX-UI2P-RS232	512253
P42-M0A-2D-1B1-220S	P42-150-BOX-RS232	512248
P42-M3A-2D-1G1-M96-M	P42-150-SET-M30-UI2P-RS232-M96	516793
P42-M3A-2D-1G1-65E	P42-800-SET-Q40-UI2P-RS232	513943
P42-M3A-2D-1G1-300E	P42-90-SET-M30-UI2P-RS232	511922
P42-M3A-2D-1G1-220S	P42-150-SET-M30-UI2P-RS232	512262
P42-M3A-2D-1G1-200E	P42-150-SET-M30-UI2P-RS232-200E	516788
P42-M3A-2D-1G1-180E	P42-250-SET-M30-UI2P-RS232	512261
P42-M3A-2D-1G1-130E	P42-400-SET-M30-UI2P-RS232	512259
P42-T4N-AD-1EF2-130E	P42-350-M30-PBT-UI2N-RS485-C723	515545
P42-T4N-AD-1EF1-130E	P42-130-M30-PBT-UI2P-RS485-C723	515544
P42-T4N-AD-1CD2-220E	P42-150-M30-PBT-UI2N-RS232-C723	515556
P42-T4N-AD-1CD2-130E	P42-350-M30-PBT-UI2N-RS232-C723	515542
P42-T4N-2D-1D1-300E	P42-60-M30-PBT-I2P-RS232-C723	515657
P42-T4N-AD-1EF2-220E	P42-150-M30-PBT-UI2N-RS485-C723	515558
P42-T4N-AD-1EF2-180E	P42-200-M30-PBT-UI2N-RS485-C723	515565
P42-T4N-AD-1EF1-220E	P42-160-M30-PBT-UI2P-RS485-C723	515557
P42-T4N-AD-1EF1-180E	P42-200-M30-PBT-UI2P-RS485-C723	515564
P42-T4N-AD-1CD2-180E	P42-200-M30-PBT-UI2N-RS232-C723	515563
P42-T4N-AD-1CD2-130E	P42-350-M30-PBT-UI2N-RS232-C723	517261
P42-T4N-AD-1CD1-220E	P42-160-M30-PBT-UI2P-RS232-C723	515637
P42-T4N-AD-1CD1-180E	P42-200-M30-PBT-UI2P-RS232-C723	515568
P42-T4N-AD-1CD1-130E	P42-350-M30-PBT-UI2P-RS232-C723	516334

## Cross-reference list PiL (old) / Honeywell

P42-T4N-2D-1F1-200E	P42-150-M30-PBT-I2P-RS485-C723	513776
P42-T4N-2D-1F1-130E	P42-350-M30-PBT-I2P-RS485-C723	516538
P42-T4N-2D-1E1-200E	P42-150-M30-PBT-U2P-RS485-C723	513775
P42-T4N-2D-1E1-130E	P42-350-M30-PBT-U2P-RS485-C723	513695
P42-T4N-2D-1D1-200E	P42-150-M30-PBT-I2P-RS232-C723	512279
P42-T4N-2D-1D1-180E	P42-200-M30-PBT-I2P-RS232-C723	514213
P42-T4N-2D-1D1-130E	P42-350-M30-PBT-I2P-RS232-C723	513972
P42-T4N-2D-1C1-200EPD	P42-150-M30-PBT-U2P-RS232-C723	515367
P42-T4N-2D-1C1-200E	P42-150-M30-PBT-U2P-RS232-C723	513574
P42-T4N-2D-1C1-180E	P42-200-M30-PBT-U2P-RS232-C723	513859
P42-T4N-2D-1C1-130E	P42-350-M30-PBT-U2P-RS232-C723	513784

**\* For Honeywell reference replace "P" with "9".**